

2008



**DONGGUAN**  
**KAIYAN**  
**HARDWARE**

东莞市凯焱五金制品有限公司  
Dongguan Kaiyan Hardware Products Co., Ltd.

Excellence in Every Endeavor  
每一份努力，都追求卓越。



# CATALOG

关于我们  
About Us

发展历程  
Development  
Process

产品介绍  
Products  
Introduction

规划与未来  
Planning and  
the Future

# About Us



东莞市凯焱五金制品有限公司

Dongguan Kaiyan Hardware Products Co., Ltd.

A source factory specializing in precision hardware stamping.

OEM/ODM



成立时间

Established in  
2008



总部

Located in  
Dongguan

核心优势

Core Advantages

With over 16 years of OEM/ODM experience, an excellent engineering and technical team, and a strict quality management system.

Staff:25+

total area:2500m<sup>2</sup>+



# Company Organization Chart

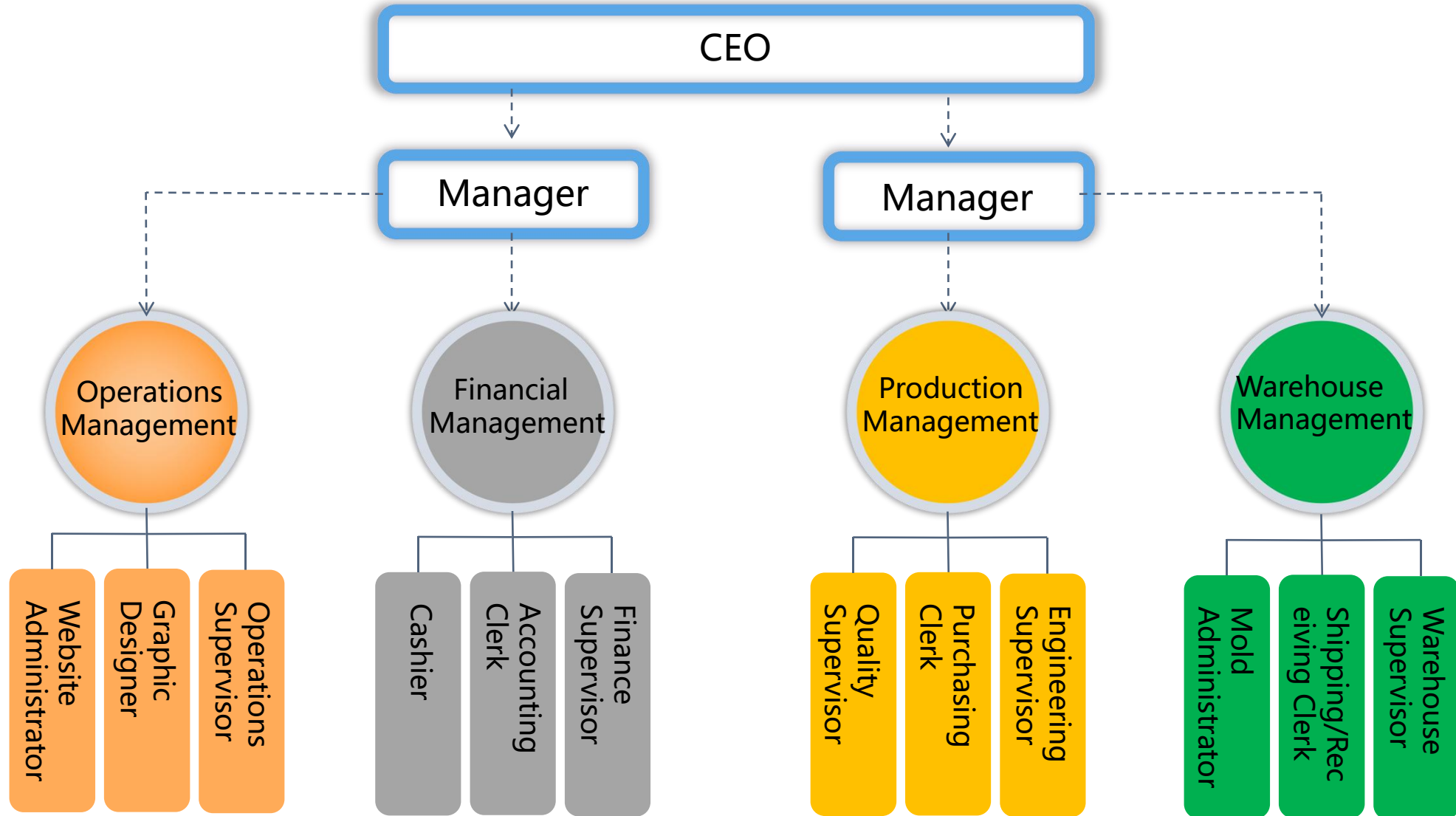

## Production workshop

- The KaiYan Factory covers an area of over 2500 square meters and is equipped with 12 high-precision pu0nch presses from well-known brands including Komatsu, King Feng, and SEYE, enabling it to control product tolerance accuracy within 0.05mm.
- Globally, we have more than 200 customers, who are widely distributed across multiple core sectors such as auto parts, electronic equipment, medical devices, and smart home.
- We have obtained the ISO 9001 Quality Management System certification, and quality serves as the cornerstone for the survival and development of our factory.



# More Displays



**High precision grinding machine room**



**Mold Storage Area**



**Deep Drawing**

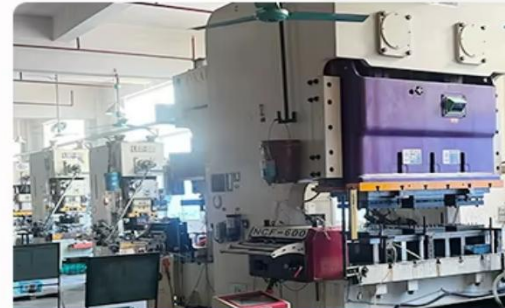

**Press Machine**



**Production Equipment**

# Supply chain quality control process

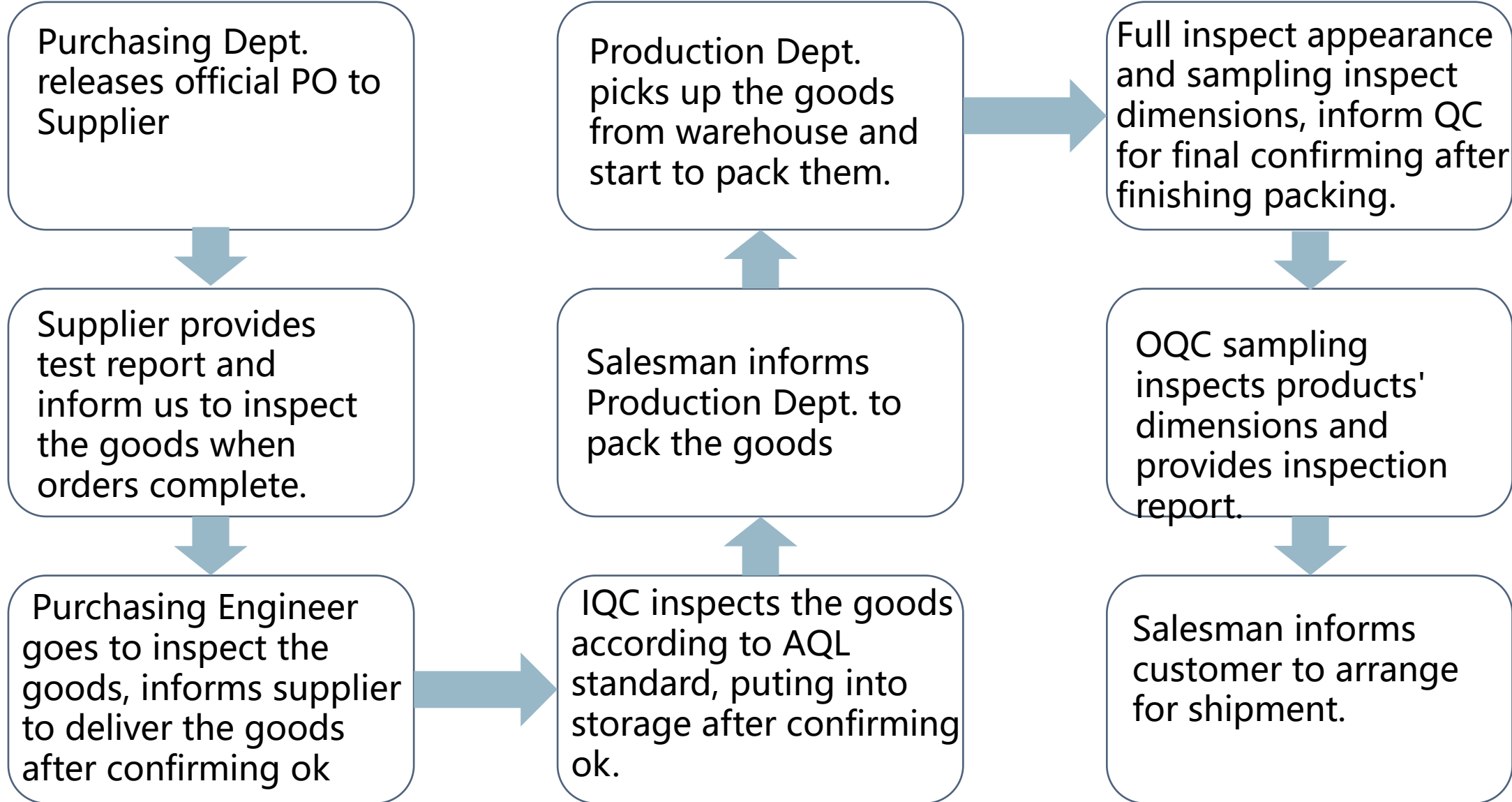

# In-Process Quality Control

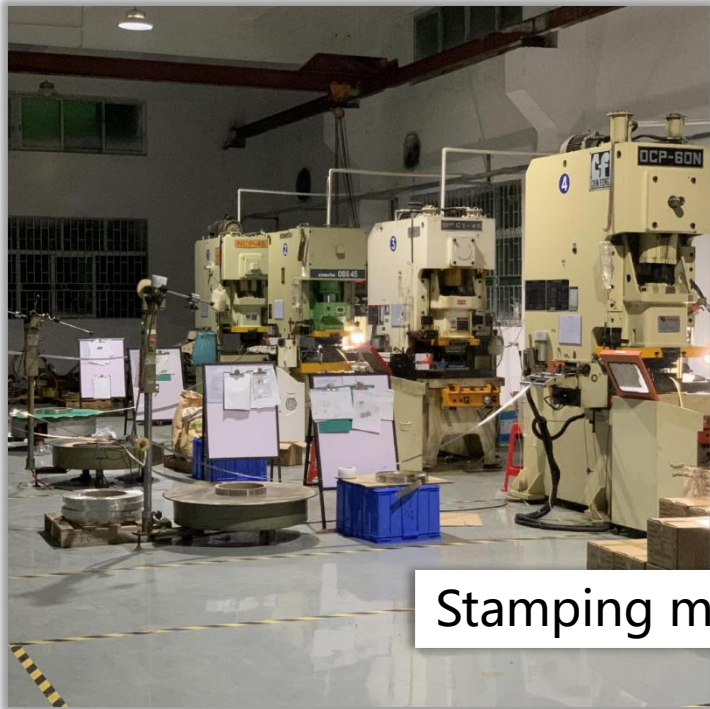

Stamping manufacturing

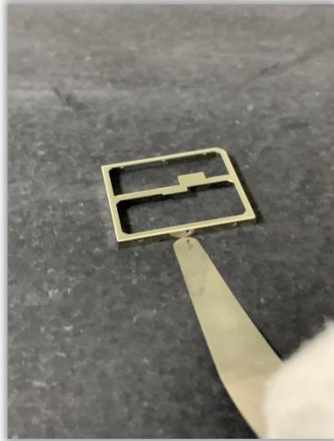

6#

IPQC首件、制程巡回检验报告

公司料号	K10328	工程别	K10328-01	工单号	60805812	班别	自
客户料号	屏散夹	客户代码	YL001	检验日期	2015.8.12	□首件	□巡回

简图:

屏散夹

项目	A	B	C	D	E	F	G	H	I	J	K	M	外观检测	判定
规格值	0.3	3.59	8.8	2.7	2.42									
公差	+0.002													
时间	0.30	0.98	3.57	8.79	2.69	2.61							合格	合格
	10:00	0.98	3.56	8.79	2.68	2.30							合格	合格
	11:30	0.98	3.57	8.79	2.68	2.31							合格	合格
	14:00	0.98	3.57	8.78	2.67	2.31							合格	合格
	15:00	0.98	3.57	8.76	2.67	2.32							合格	合格
	16:00	0.98	3.58	8.78	2.66	2.32							合格	合格

标准值: \_\_\_\_\_ 公差: \_\_\_\_\_ 实测值: \_\_\_\_\_ 判定: \_\_\_\_\_

备注: \_\_\_\_\_

审核: \_\_\_\_\_

QC: 许智斌  
QA-QR-002

VER: A0

# Testing Equipments



Temperature testing machine



Image Measuring Instrument



Mituoyo Projector



Tensile Tester



Portable Film Thickness Meter



Precision Altimeter



Micro Vickers Hardness Tester



Rockwell Hardness Tester



Torsion Tester



Salt Spray Test

# The Development

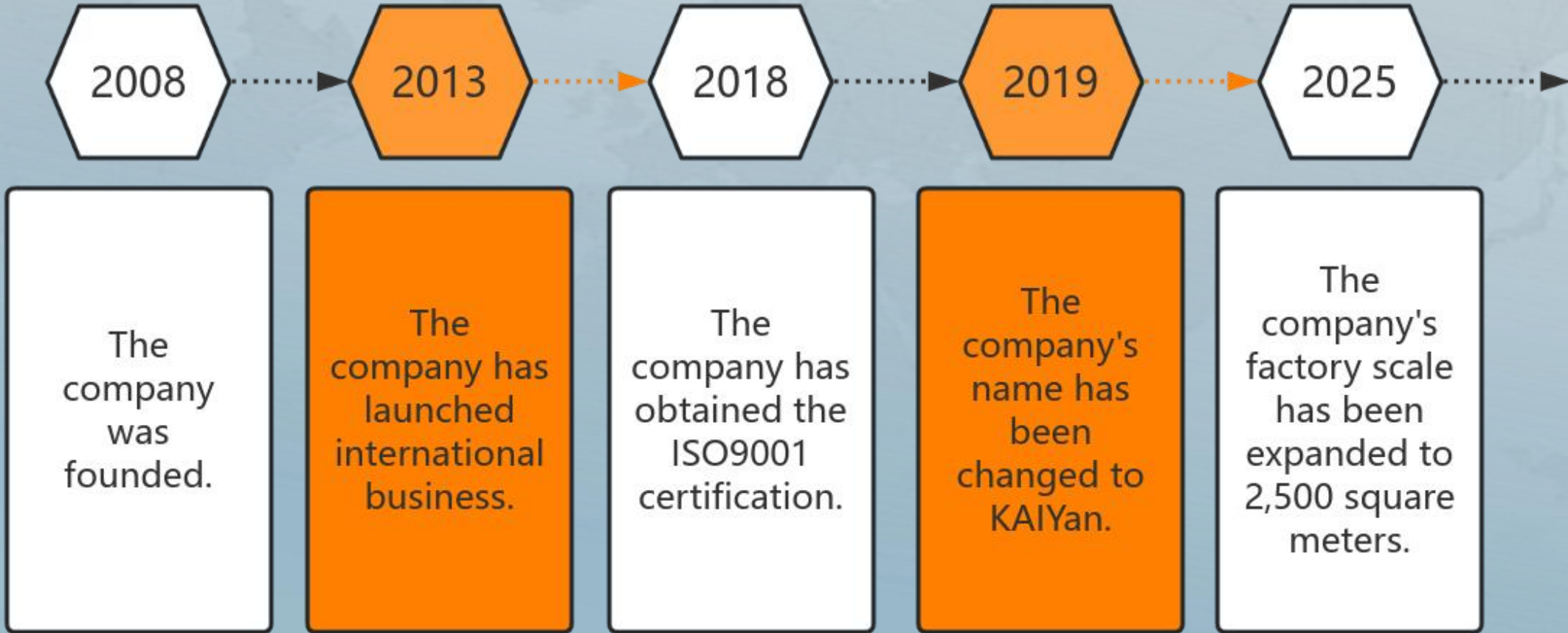

# Products Introduction



## RF SHIELD



Stamping Die



Stainless steel  
RF shield cover



Nickel silver  
shielding cover



Stretchable  
RF Shield Frame



65MN  
Shielding Clip



Tinplate RF  
shielding cover



Product  
tape packaging



Anti-static  
tray packaging



Application  
Scenario (PCB Board)

# More Displays

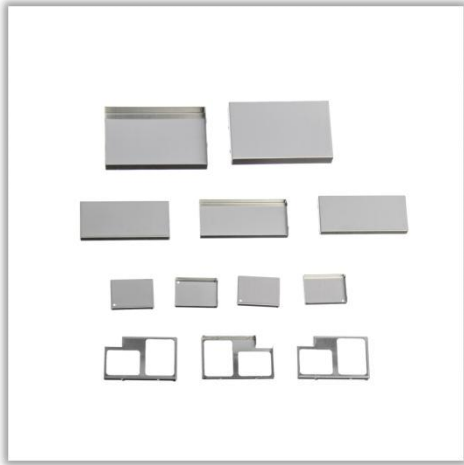

RF Shield  
Products

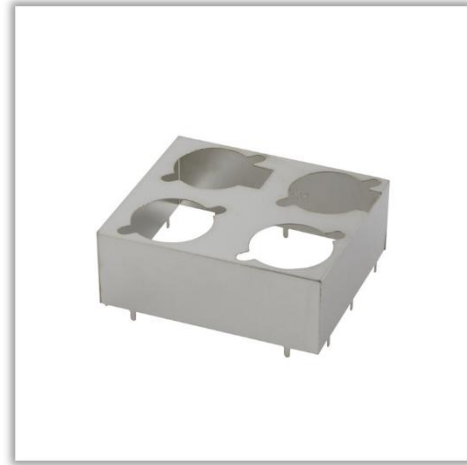

RF Shield  
Products

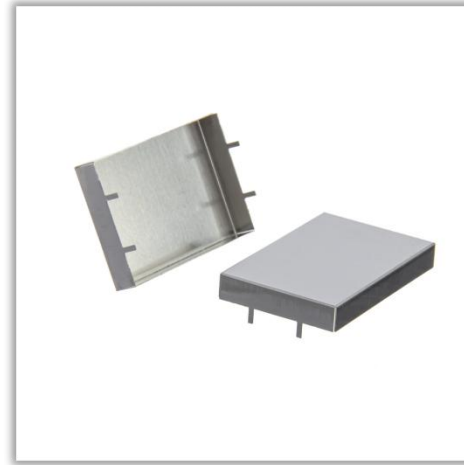

RF Shield  
Products

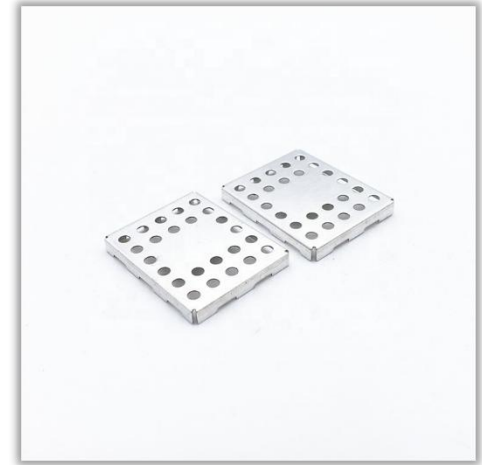

RF Shield  
Products

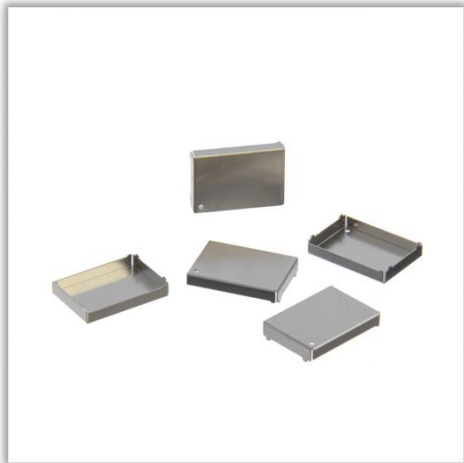

RF Shield  
Products



RF Shield  
Products



RF Shield  
Products



RF Shield  
Products

# Metal Chassis/Enclosure



Customed  
metal enclosure



Customized  
metal panel

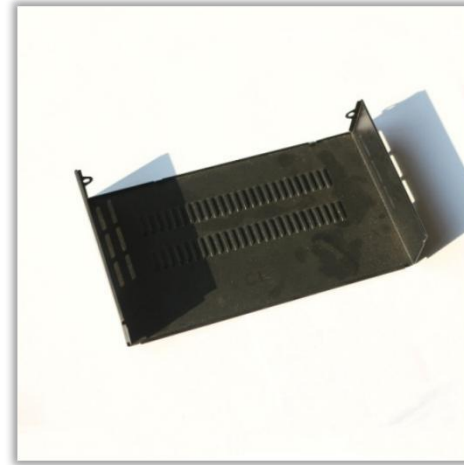

Customized  
metal chassis

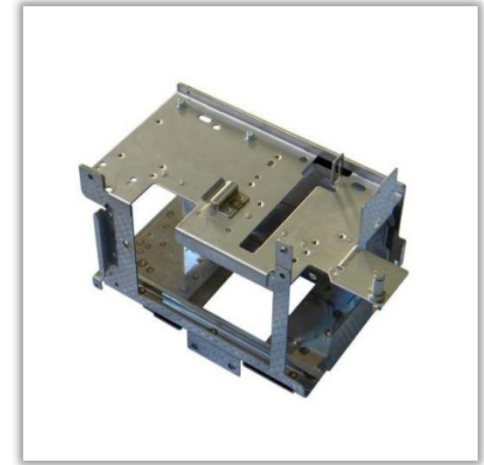

Customed  
metal enclosure



Customized  
server chassis



Customized  
metal panel

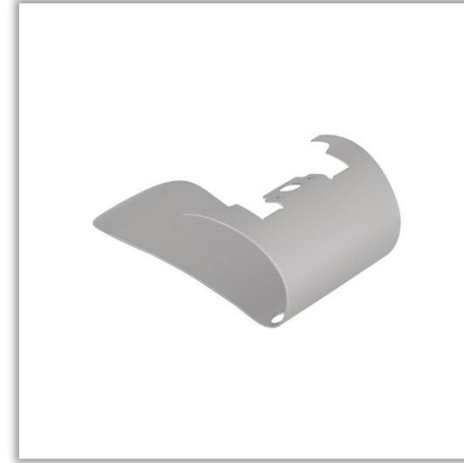

Customed  
metal enclosure



Customized  
metal chassis

# More Displays



Customed  
metal enclosure



Customized  
metal panel



Customized  
metal chassis



Customed  
metal enclosure

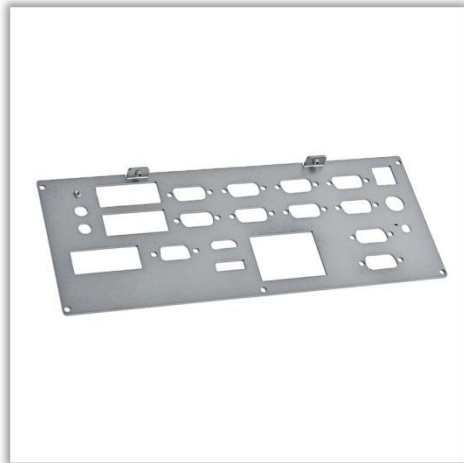

Customized  
metal panel



Customized  
metal panel



Customized  
metal panel



Customed  
metal enclosure

# Socket and Switch Accessories



British  
standard shrapnel



American  
Standardshrapnel



Eurocode  
standard shrapnel



Australian standard  
shrapnel



32A electric  
contact shrapnel



16A electric  
contact shrapnel



10A electric  
contact shrapnel



Ag90Ni10  
contact

# More Displays



Nickel-plated  
spring plate



Plug contact  
plate



Customized  
spring plate



Customized  
spring plate



Gold-plated  
spring plate



Socket Panel  
Accessories

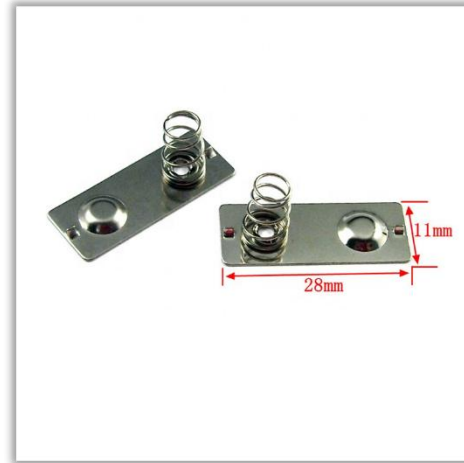

Battery Spring  
Contact



European-standard  
spring plate

# Crimp terminal



crimp terminal



brass crimp terminal



iron crimp terminal



brass crimp terminal



brass crimp terminal



crimp terminal



crimp terminal



crimp terminal

# Door and window hinges



door and window hinges



door and window hinges



door and window hinges



door and window hinges



door and window hinges



door and window hinges



door and window hinges



door and window hinges

# Drawn part



motor housing



copper drawn part



iron drawn part



motor housing



Stainless steel drawn part



copper drawn part



Stainless steel drawn part



Aluminum deep-drawn parts

# Chemical etching

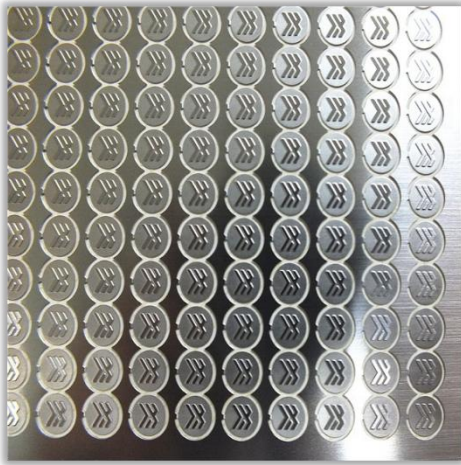

Stainless steel  
etching



Aluminum  
etching

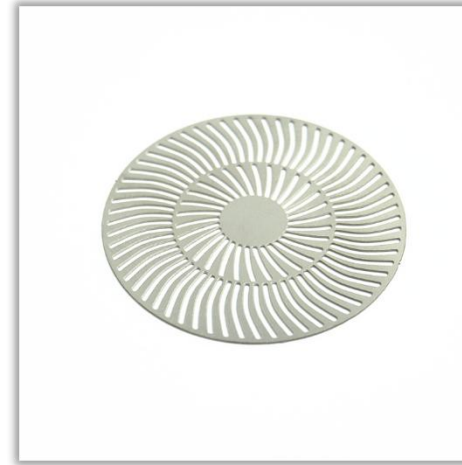

Aluminum  
etching



Stainless steel  
etching



Brass  
etching



Bipolar  
plate



Stainless steel  
drawn part



Stainless steel  
etching

# PCB Terminal/Screw Busbar Terminal



PCB  
Terminal



PCB  
Terminal



PCB  
Terminal



PCB  
Terminal



Screw  
buckle



Screw Busbar  
Terminal



Screw Busbar  
Terminal

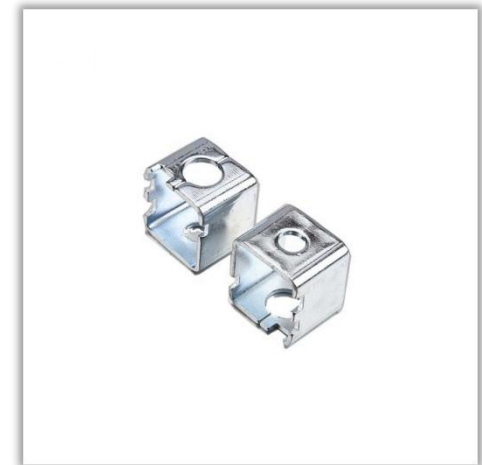

Screw Busbar  
Terminal

# Precision spring



Tension  
Spring



Battery Positive  
Spring



Battery  
Spring



Tower  
Spring



Radiator  
Buckle

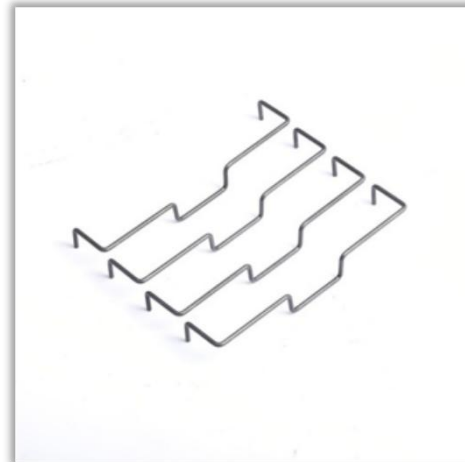

Thread  
Forming

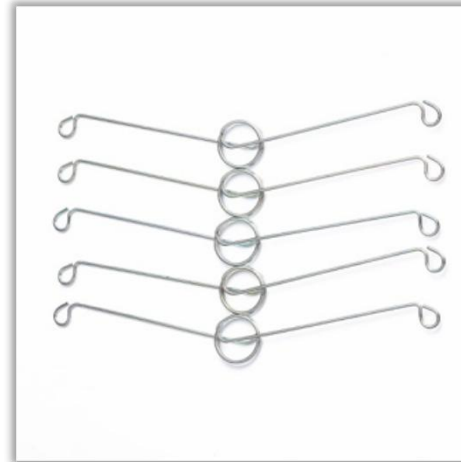

Special Shaped  
Spring



Torsion  
Spring

# Aluminum extrusion

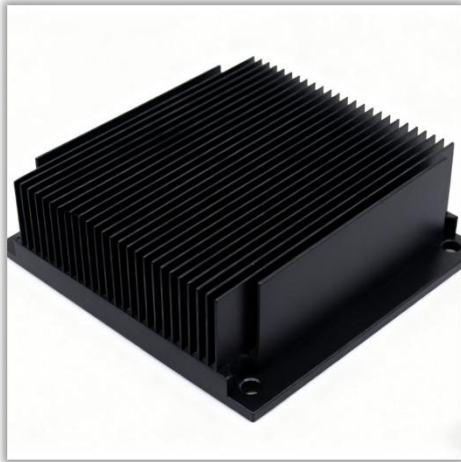

Aluminum  
heat sink

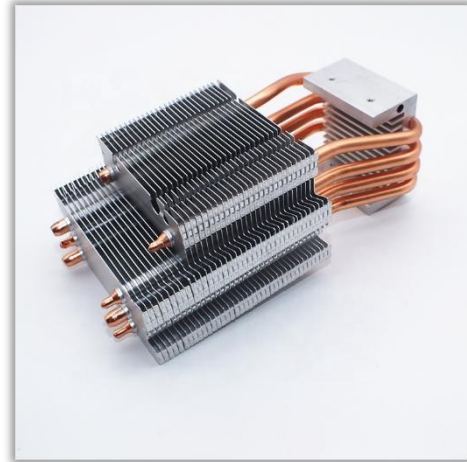

Copper tube  
radiator

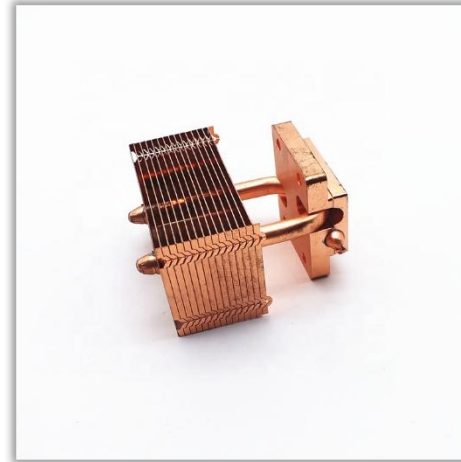

Copper  
heat sink



Aluminum  
heat sink

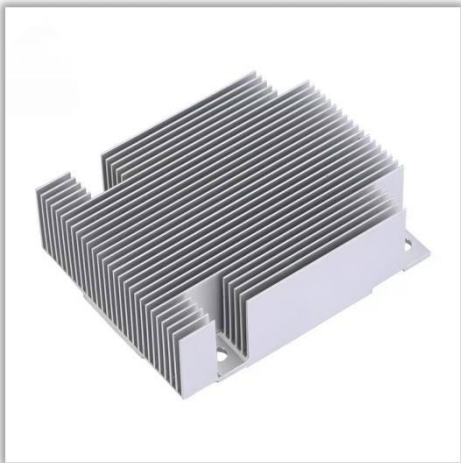

Aluminum  
heat sink



Aluminum heat  
sink



Aluminum heat  
sink



Copper  
heat sink

# Die casting



Die-cast  
door handle



Die-cast watch  
decorative parts



Die-cast watch  
decorative parts



Die-cast  
ornaments



Die-cast  
housing



Die-cast  
housing



Die-cast  
part



Engine  
casing

# CNC machined parts



Tension  
Spring



Battery Positive  
Spring



Battery  
Spring



Tower  
Spring



Radiator  
Buckle



Thread  
Forming



Special Shaped  
Spring



Torsion  
Spring

# The Service Concept of KY



Service philosophy: rapid response, timely replies!

Email: replying within 24 working hours

Customer Complaint Handling Process:

1. Quick Response: Upon receiving a complaint, the relevant person in charge shall take the lead within 2 hours to organize a short meeting with relevant colleagues (such as product, technology, and customer service).

2. Identify the Cause: The focus of the meeting is to quickly locate the root cause of the problem and determine whether it is a product defect, service error, or communication misunderstanding.

3. Provide a Solution: Within 48 hours, the customer service or dedicated account manager shall clearly inform the customer of the solution.

# Team Building Activities



# Planning and the Future



## **Production Objectives**

Optimize the production process, introduce automated production lines, increase production efficiency by more than 30%, reduce production costs by approximately 15%, achieve green production, and meet the industry's environmental protection standards.

## **Conduct New Product R&D**

Based on the needs of downstream industries, develop high-precision and high-value-added stamping products, such as automotive lightweight stamping parts and electronic precision stamping parts, to meet the diverse needs of the market.

## **Building a Positive Corporate Culture**

Advocate the corporate culture of "people-oriented, innovative development, and pursuit of excellence", strengthen communication and collaboration among employees, and enhance their sense of belonging and cohesion. Organize a variety of corporate cultural activities to create a positive and progressive working atmosphere.

**Contact Us**



**DONGGUAN**  
**KAIYAN**  
**HARDWARE**

**Dongguan Kaiyan Hardware Products Co., Ltd.**

**Adds: 119, No. 1-1 Qiantan Second Street, Shipai Town**

**Email: [info@kyhardware.com](mailto:info@kyhardware.com)**

**Tel: +86 13412060898**

**WhatsApp: +86 13412060898**

**Thank you for watching!**