

ATGET® 雅之杰®

广州市雅之杰装饰五金有限公司

ATGET DECORATION & HARDWARE CO.,LTD

E-mai: atget@atgetco.com

<http://www.atgetco.com>

Company address: Unit 66-5, No.200 Fangcun Avenue East, Liwan District, Guangzhou 510378, China

Factory address: No.1 Keyunzhong Road, Area A of Shishan Industry Park, Nanhai District, Foshan City, China

2021
YEAR

PRODUCT CATALOG

304 stainless steel precision

ATGET® 雅之杰®

PAPER TOWEL DISPENSER
AESTHETIC DESIGN, THE BEAUTY OF ART



SUS304 STAINLESS STEEL, BRUSHED
ALLOY LOCK DESIGN
CIRCULAR ARC LARGE PAPER OUTLET

TD-83328
PAPER TOWEL DISPENSER



- Pass 240-Hour Salt Spray Test
- Capacity 250 sheets of C or Z fold tissue
- Main Material: 304 stainless steel
- Surface processing: Satin finished

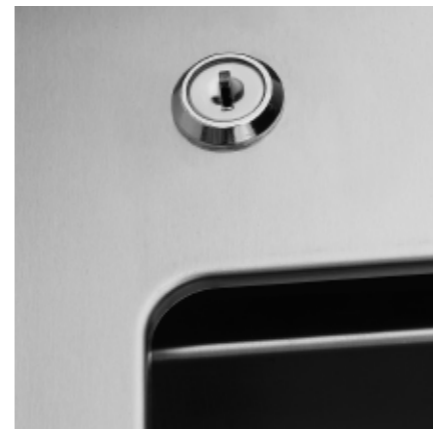
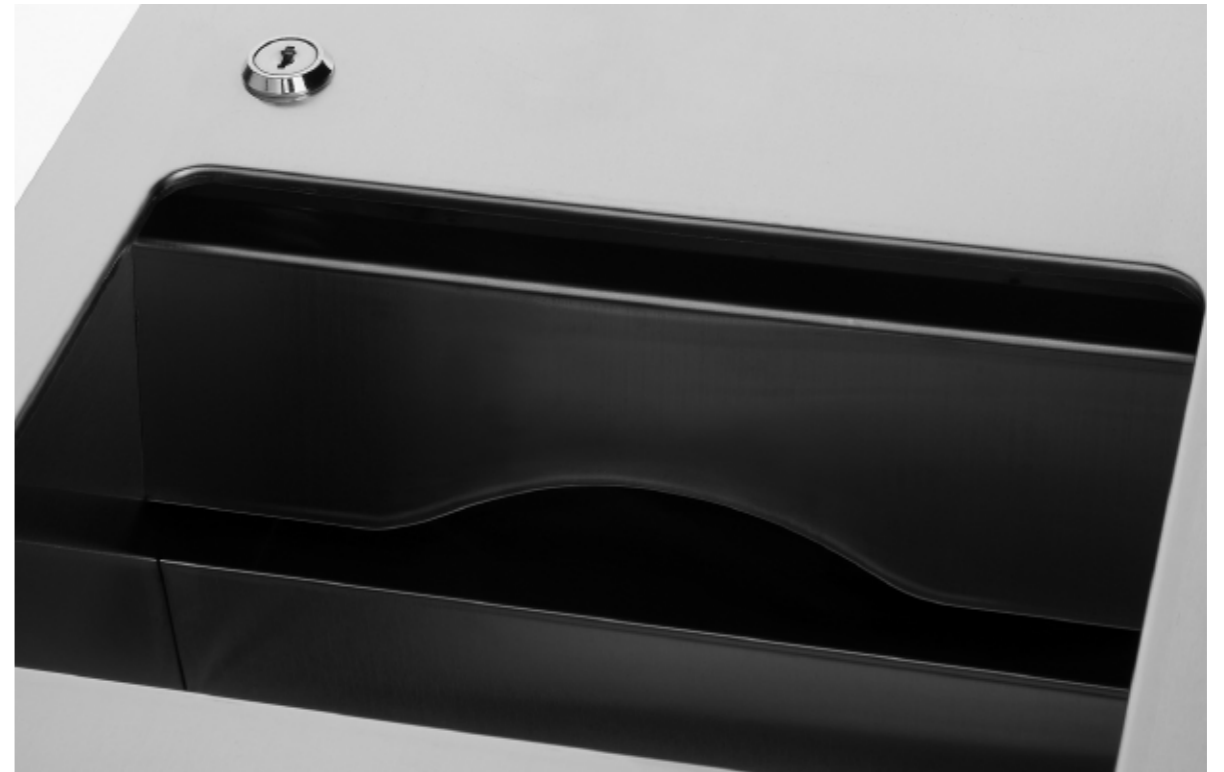
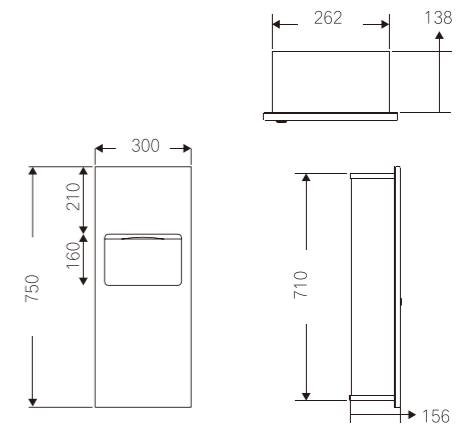

PAPER TOWEL DISPENSER
AESTHETIC DESIGN, THE BEAUTY OF ART

AT6ET. 雅之杰.



SUS304 STAINLESS STEEL, BRUSHED
ALLOY LOCK DESIGN
HIGH CAPACITY, WALL MOUNTED DESIGN
CIRCULAR ARC LARGE PAPER OUTLET

TD-8314A
PAPER TOWEL DISPENSER



Pass 240-Hour Salt Spray Test

Capacity 400 sheets of C or Z fold tissue

Main Material: 304 stainless steel

Surface processing: Satin finished

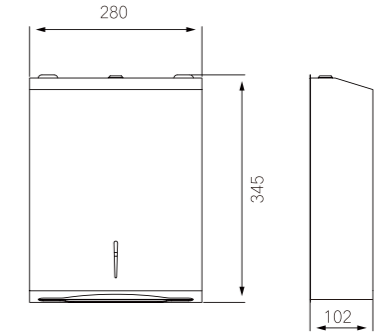

TD-8313A
PAPER TOWEL DISPENSER



Pass 240-Hour Salt Spray Test

Capacity 250 sheets of C or Z fold tissue

Main Material: 304 stainless steel

Surface processing: Satin finished

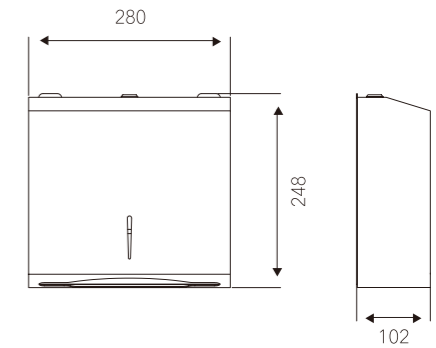

JUMBO-ROLL TISSUE DISPENSER
AESTHETIC DESIGN, THE BEAUTY OF ART

AT6ET. 雅之杰.

TD-8300A
JUMBO-ROLL TISSUE DISPENSER



Pass 240-Hour Salt Spray Test

Capacity 200-Meter of Paper Towel

Main Material: 304 stainless steel

Surface processing: Satin finished

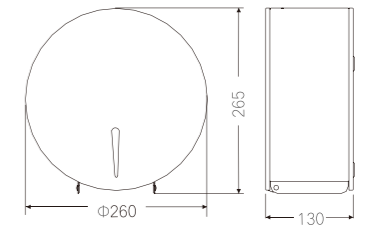

TD-8330A
JUMBO-ROLL TISSUE DISPENSER



Pass 240-Hour Salt Spray Test

Capacity 400-Meter of Paper Towel

Main Material: 304 stainless steel

Surface processing: Satin finished

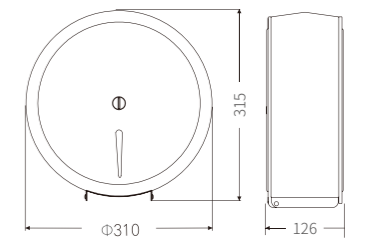

SUS304 STAINLESS STEEL, BRUSHED
ALLOY LOCK DESIGN
HIGH CAPACITY, WALL MOUNTED DESIGN
CIRCULAR ARC LARGE PAPER OUTLET

LIQUID SOAP DISPENSER ORIGINALITY AND ARTISTICALLY



304 STAINLESS STEEL
TRANSPARENT WINDOW DESIGN
WALL MOUNTED DESIGN
PUSHED PUMP

ATGET. 雅之杰.

SD-1080(1250ml) SOAP DISPENSER



Pass 240-Hour Salt Spray Test

Duration 1,000,000 circles

Main Material: 304 stainless steel

Surface processing: Polish finished,Satin finished

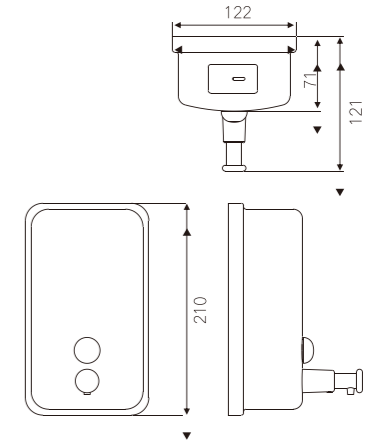

SD-680(800ml) SOAP DISPENSER



Pass 240-Hour Salt Spray Test

Duration 1,000,000 circles

Main Material: 304 stainless steel

Surface processing: Polish finished,Satin finished

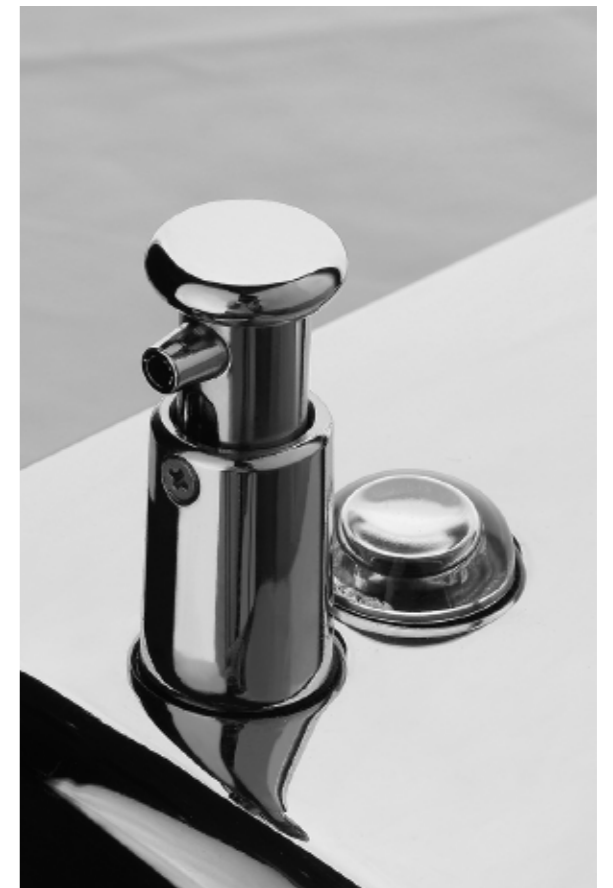
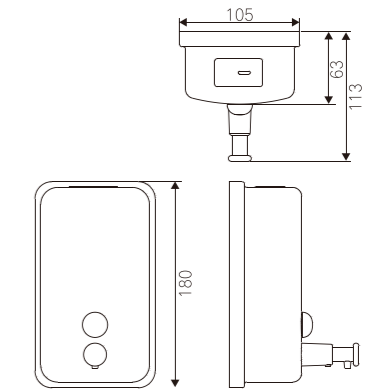

**LIQUID SOAP DISPENSER
MADE WITH INGENUITY, BEAUTIFUL AND ATMOSPHERIC**

AT6ET. 雅之杰.

SD-1080WS(1250ml)
SOAP DISPENSER

Pass 240-Hour Salt Spray Test

Duration 1,000,000 circles

Main Material: 304 stainless steel

Surface processing: Polish finished,Satin finished

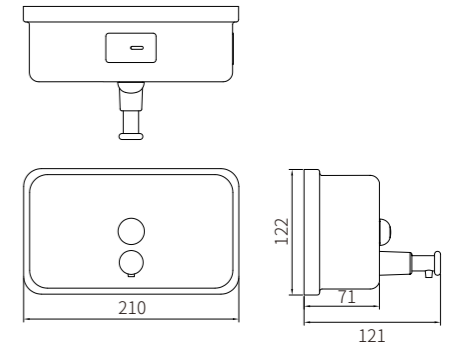

304 STAINLESS STEEL
TRANSPARENT WINDOW DESIGN
WALL MOUNTED DESIGN
PUSHED PUMP

LIQUID SOAP DISPENSER
MADE WITH INGENUITY, BEAUTIFUL AND ATMOSPHERIC

AT6ET. 雅之杰.

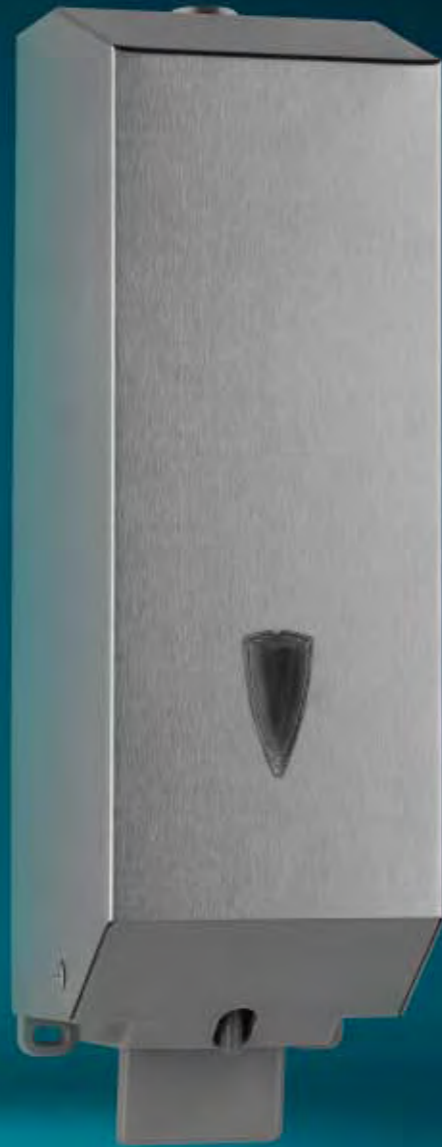

SD-1090(1000ml)
SOAP DISPENSER



- Pass 240-Hour Salt Spray Test
- Capacity 1000ml
- Duration 300,000Circles
- 0.20ml each drop
- Main Material: SUS304 and ABS
- Surface processing: Polish finished,Satin finished

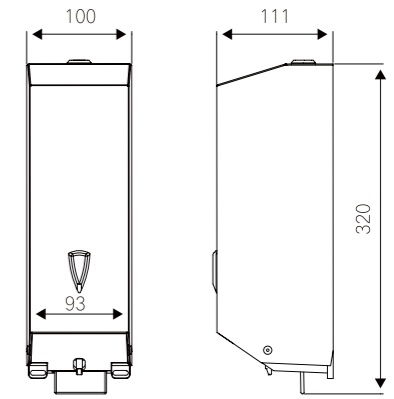

SUS304 STAINLESS STEEL
TRANSPARENT ABS WINDOW
ORIGINAL PULL STYLE
WALL MOUNTED DESIGN

HANDRAIL
STRONG AND SECURE

ANH-A75B
BATHROOM GRAB BAR



Pass 240-Hour Salt Spray Test

Loading 200KG

Main Material: 304 stainless steel

Surface processing: Satin finished

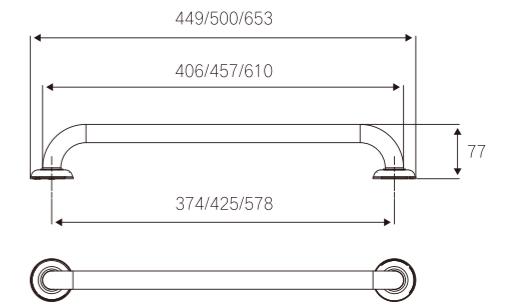

BNH-19020
BATHROOM GRAB BAR



Pass 240-Hour Salt Spray Test

Loading 200KG

Main Material: 304 stainless steel

Surface processing: Polish finished, Satin finished

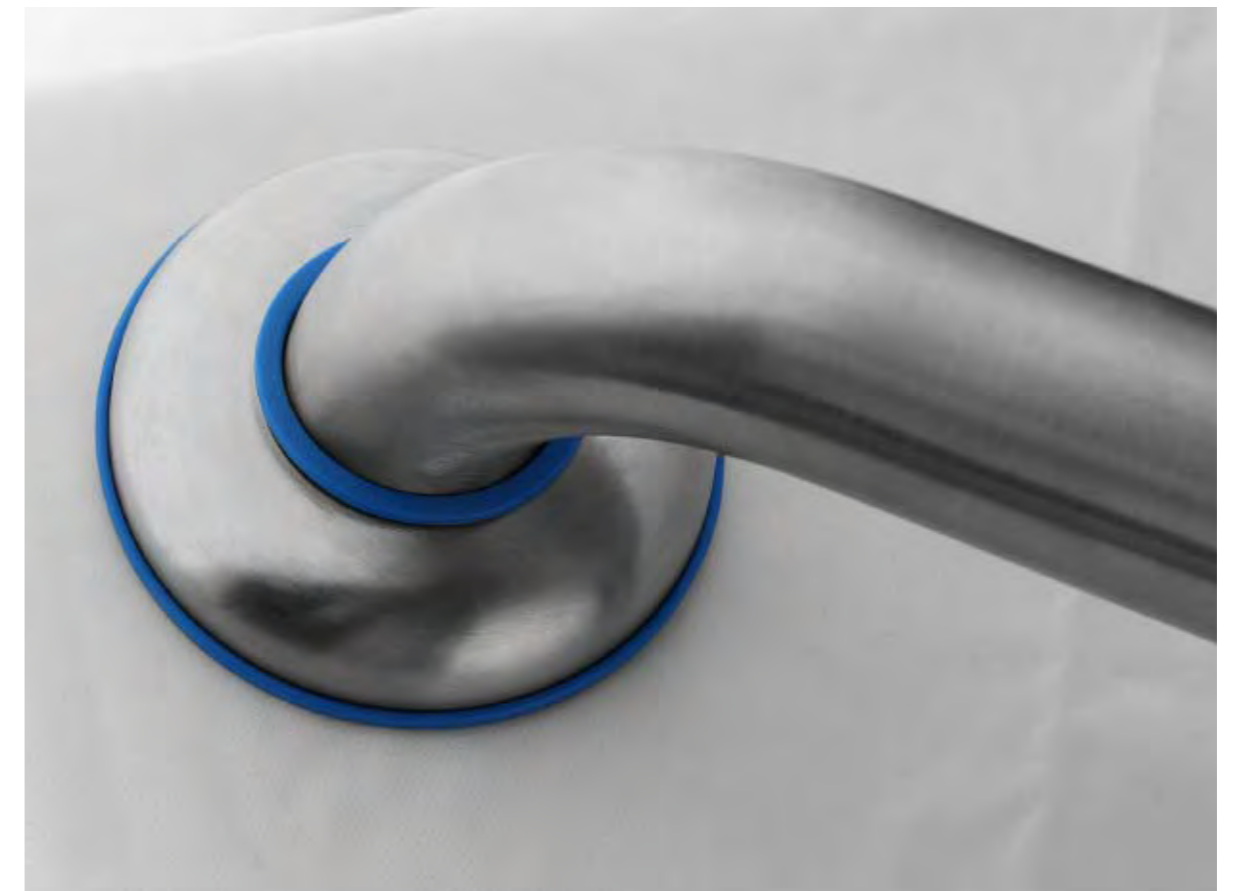
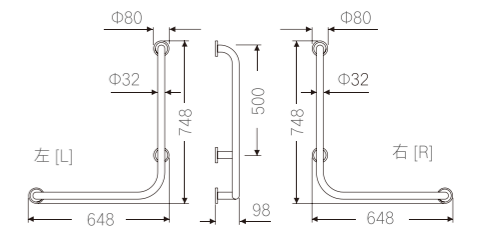

SUS304 STAINLESS STEEL
COMFORTABLE
DURABILITY

HANDRAIL
STRONG AND SECURE

ATGET. 雅之杰.

BNH-9035
SWING-UP HANDRAIL

Pass 240-Hour Salt Spray Test
Loading 200KG
Duration 20,000 Circles
TUV Test Certificated
Main Material: 304 stainless steel
Surface processing: Polish finished,Satin finished

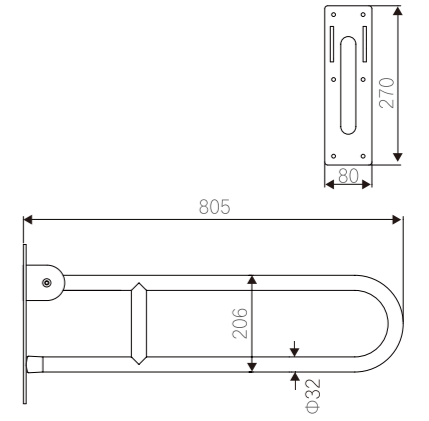

BNH-9032
SWING-UP HANDRAIL

Pass 240-Hour Salt Spray Test
Loading 150KG
Duration 200,000Circles
TUV Test Certificated
Main Material: 304 stainless steel
Surface processing: Polish finished,Satin finished

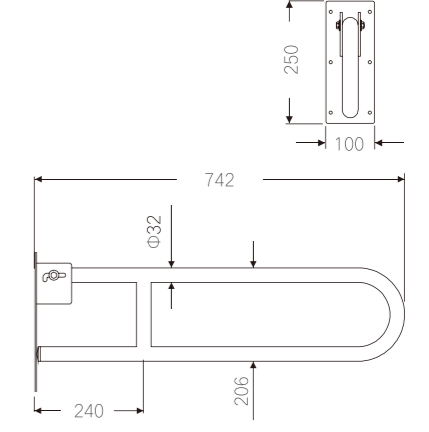
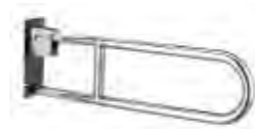

SUS304 STAINLESS STEEL
COMFORTABLE
DURABILITY

WASTEBIN
DURABLE AND HIDDEN

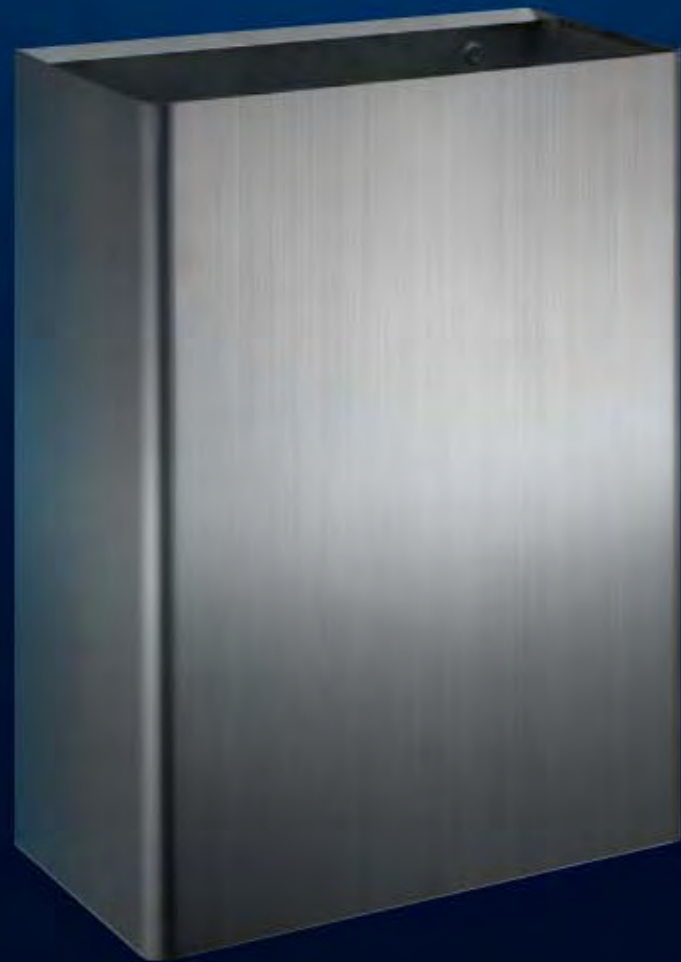

SUS304 STAINLESS STEEL
WIDE OPENING
HIGH CAPACITY
HERMETIC BOTTOM

XT02-K380
WASTEBIN



Pass 240-Hour Salt Spray Test

Main Material: 304 stainless steel

Surface processing: Satin finished

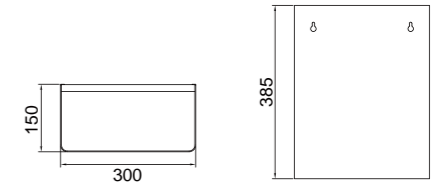

RETRACTABLE CLOTHESLINE
REAL MATERIAL, EXTRAORDINARY QUALITY

AT6ET. 雅之杰.

CL-4188A
RETRACTABLE CLOTHES LINE

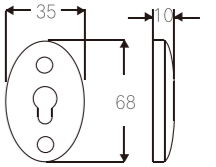

Pass 240-Hour Salt Spray Test

Nylon Rope With 2.5M

Loading 5 KGS

Main Material: 304 stainless steel

Surface processing: Polish finished,Satin finished

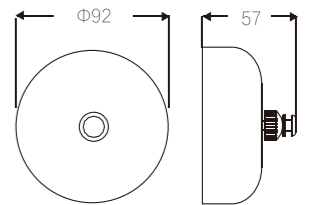

304 STAINLESS STEEL FOUNDATION
STRONG AND TOUGH NYLON ROPE
STRONG BEARING CAPACITY
FLEXIBLE

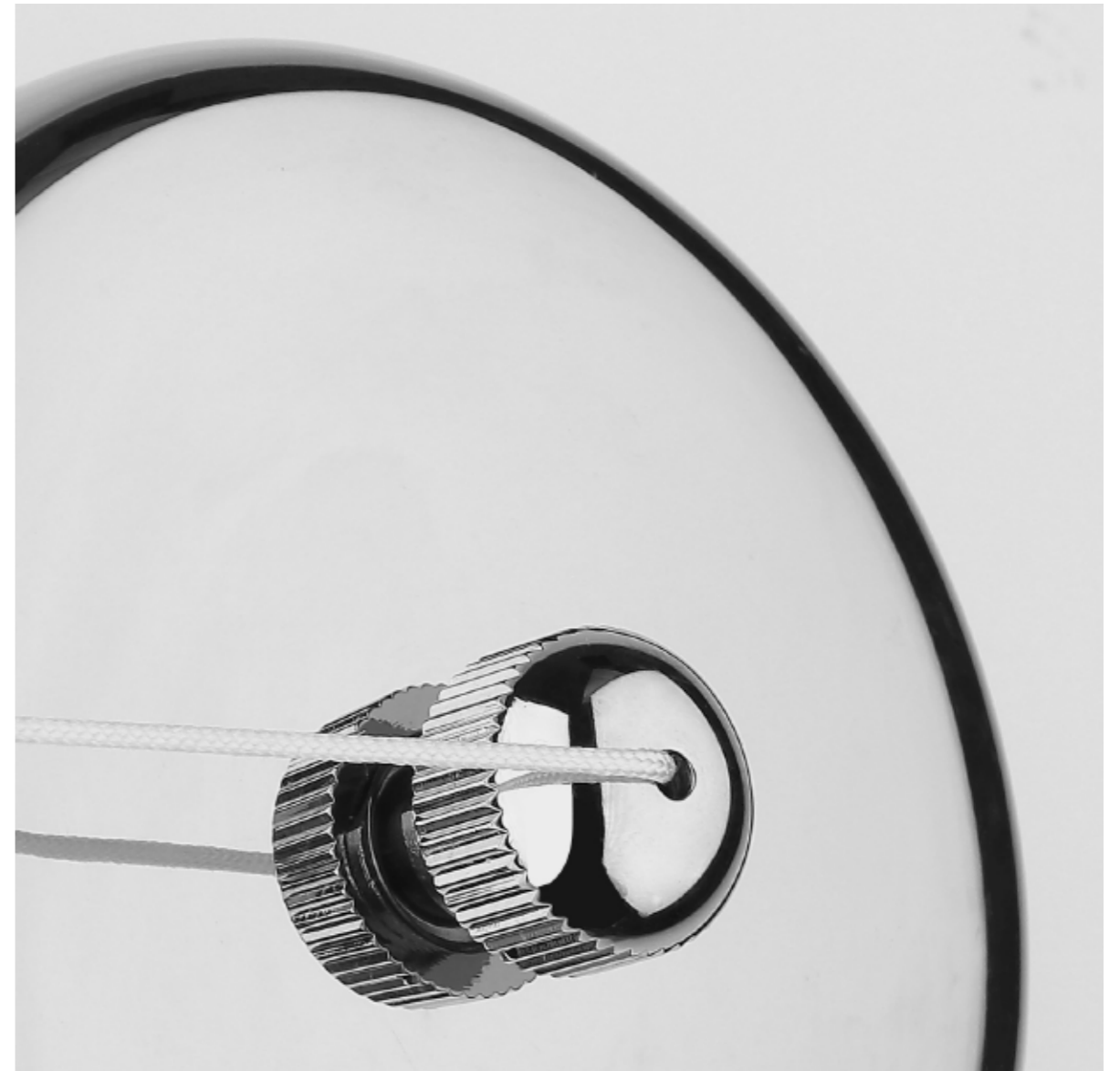

PAPER HOLDER (WITH PLATFORM)
CHOICE OF STYLE , HOME STORAGE



304 STAINLESS STEEL
FINE ROUNDED CORNERS
EASY STORAGE
STURDY AND DURABLE

AS01-A021K
PAPER HOLDER (WITH PLATFORM)



Pass 240-Hour Salt Spray Test

Main Material: 304 stainless steel

Surface processing: Satin finished

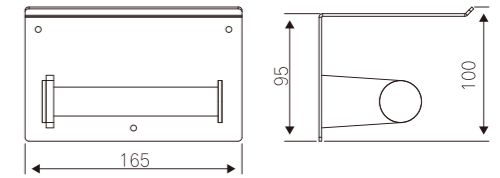

AS01-A021
PAPER HOLDER (WITH PLATFORM)



Pass 240-Hour Salt Spray Test

Main Material: 304 stainless steel

Surface processing: Polish finished

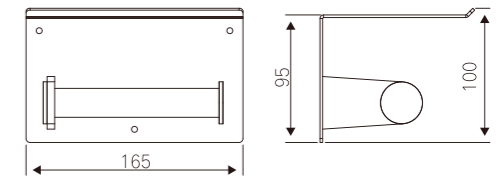

DOUBLE PAPER HOLDER
CHOICE OF STYLE , HOME STORAGE

AT6ET. 雅之杰.

AS01-A022WK
DOUBLE PAPER HOLDER
(WITH PLATFORM)



Pass 240-Hour Salt Spray Test

Main Material: 304 stainless steel

Surface processing: Satin finished

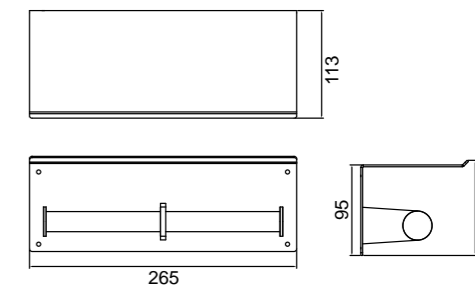

AS01-A022W
DOUBLE PAPER HOLDER
(WITH PLATFORM)



Pass 240-Hour Salt Spray Test

Main Material: 304 stainless steel

Surface processing: Polish finished

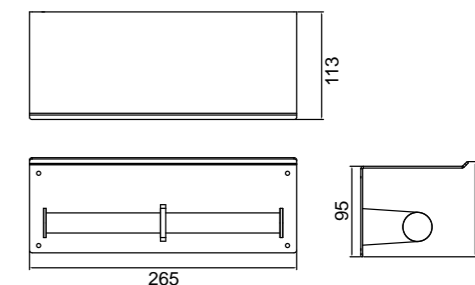

304 STAINLESS STEEL
FINE ROUNDED CORNERS
NO PUNCHING WALL MOUNTED
LARGE SHELF TABLE TOP



ROBE HOOK
COMPACT AND LIGHTWEIGHT, MINIMALIST BEAUTY

AT6ET. 雅之杰.

ROBE HOOK



Pass 240-Hour Salt Spray Test

Main Material: 304 stainless steel

Surface processing: Polish finished, Satin finished

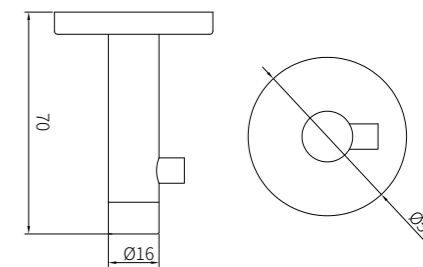

304 STAINLESS STEEL
MULTIFUNCTIONAL DESIGN
SATIN PROCESS AND RUBBER TIP
PRACTICAL SAFETY, FIRM AND STICK TO THE WALL



ROBE HOOK
COMPACT AND LIGHTWEIGHT, MINIMALIST BEAUTY



304 STAINLESS STEEL
WATERPROOF AND MOISTURE-PROOF EASY TO CLEAN
NO PUNCHING STURDY AND DURABLE
SAVE SPACE STRONG BEARING CAPACITY

AT6ET. 雅之杰.

ROBE HOOK



Pass 240-Hour Salt Spray Test

Main Material: 304 stainless steel

Surface processing: Polish finished,Satin finished

