

我们的愿景：成为办公机具龙头企业
我们的使命：打造比第二更优的产品
我们的价值观：尊重、专注、包容

www.bindking.com www.rayson.com.cn



公司网站



Company website



微信公众平台

RAYSON ELECTRICAL MFG. LTD.

TangCun Ind. Estate, NanHai, FoShan, GuangDong, China
Tel.: (+86 757) 85103082
Fax.: (+86 757) 85103635
Email: inf@rayson.com.cn
Web: http://www.rayson.com.cn



RAYSON ELECTRICAL MFG. LTD.
雷盛五金电器有限公司

用互联网+办公机具 为产品导向,以工业 4.0 为目标



雷盛® 从产品设计到研发制造，从市场拓展到售后服务，每个环节凝聚着“比第二更好”的雷盛精神。我们永不停止技术进步，服务进步。

我们专注于办公类的小型机器设备生产与研究；我们秉承为办公场所提供安全、方便的机器设备为己任；我们将用心聆听大家对我们所有的心声！



Introduction

Rayson electrical MFG. LTD.



佛山市南海和顺雷盛五金电器有限公司国内装订机行业著名生产企业，雷盛牌装订机系列产品在国内市场独占鳌头。国外市场RAYSON 品牌已经成功打入俄罗斯，东南亚，东欧市场。

雷盛集研发，生产，营销于一身。主要产品有：装订机，订书机，塑封机，碎纸机，耗材 5大系列。公司累计拥有超过20项实用新型及发明专利。雷盛以雄厚的实力、合理的价格、最优良的售前售后服务与多家企业建立了长期的合作关系。雷盛热诚欢迎各界新老客户，同行前来参观、考察、洽谈业务。

RAYSON ELECTRICAL MFG. LTD. is the star company of the binding and laminating products in China. The products brand 雷盛 are taken off in China market. The RAYSON brand had successful march into Russia, S.E. Asia, Eastern Europe, South America. RAYSON well combined the R&D, production, marketing together. Our main products are: Binding machine, Stapler, Laminator, Paper shredder, Accessories. And we keep extending the lines. RAYSON has the ability to take the order for OEM ODM from world wide customers for the world wide markets, RAYSON's products are always with the right price & high quality.

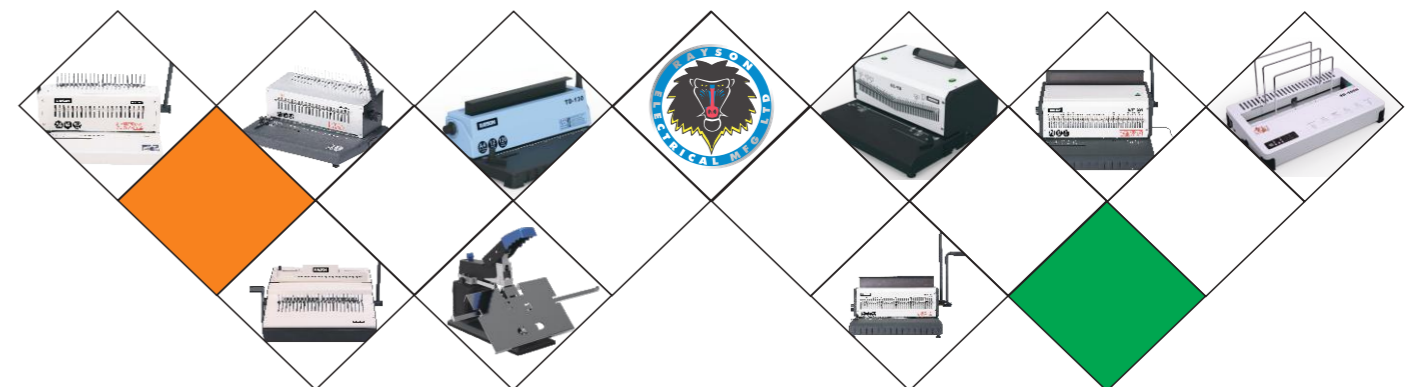



COMB BINDER (胶圈装订机)

www.bindking.com www.rayson.com.cn

SD-1501A21

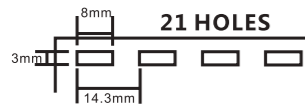

- A4** Punching up to 15 sheets 80g A4 per time.
- 200** Binding up to 200 sheets A4 paper. With special strong steel punching handle.
- 21** blades free pin for multi punching.

SD-1201

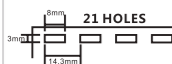

- A4** Punching up to 12 sheets 80g A4 per time.
- 200** Binding up to 200 sheets A4 paper. With special strong steel punching handle.

SD-2000

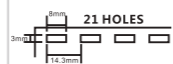

- A4** Punching up to 20 sheets 80g A4 per time.
- 200** Binding up to 400 sheets A4 papers. 3 sections margin
- 21** blades free pin for multi punching



COMB BINDER (胶圈装订机)



www.bindking.com www.rayson.com.cn

SD-2011B21

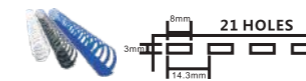

- A4** Punching up to 20 sheets 80g A4 per time.
- 200** Binding up to 400 sheets A4 papers. 3 sections margin.
- 21** blades free pin for multi punching

SD-2501B21

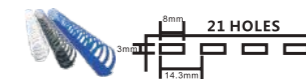

- A4** Punching up to 25 sheets 80g A4 per time.
- 200** Binding up to 400 sheets A4 papers. 3 sections margin.
- 21** blades free pin for multi punching

SD-2021B24

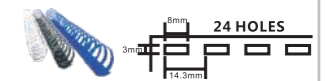

- F4** Punching up to 20 sheets 80g F4 per time.
- 200** Binding up to 400 sheets F4 papers. 3 sections margin.
- 24** blades free pin for multi punching

W-25

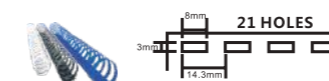

- A4** Punching up to 20 sheets 80g A4 per time.
- 220** Binding up to 220 sheets A4 papers.
- 3** blades free pin for multi punching.

EB-20

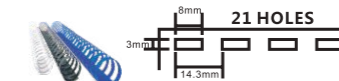

- A4** Punching up to 18 sheets 80g A4 paper.
- 200** Binding up to 400 sheets A4 paper. 3 sections margin.
- 21** blades free pin for multi punching.
- Electrical punching, easy operation.

EB-30

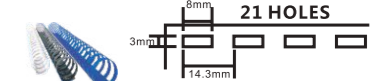

- A4** Punching up to 30 sheets 80g A4 paper.
- 200** Binding up to 400 sheets A4 paper. 3 sections margin.
- 21** blades free pin for multi punching
- Electrical punching, easy operation.



WIRE BINDER (铁圈装订机)

www.binding.com www.rayson.com.cn

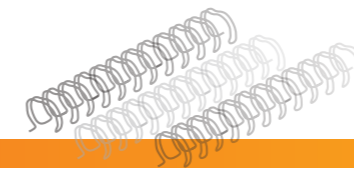

WIRE BINDER (铁圈装订机)



www.binding.com www.rayson.com.cn

TD-130

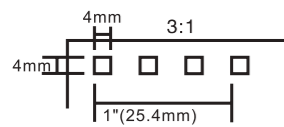

12 **A4** Punching up to 12 sheets per time Max.
120 Binding up to 120 sheets A4 papers Max.

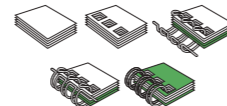

TD-1200/TD-1200R

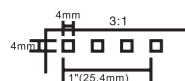

12 **A4** Punching up to 12 sheets per time Max.
120 Binding up to 120 sheets A4 papers Max.

TD-1500B34/TD-1500B34R

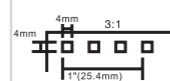
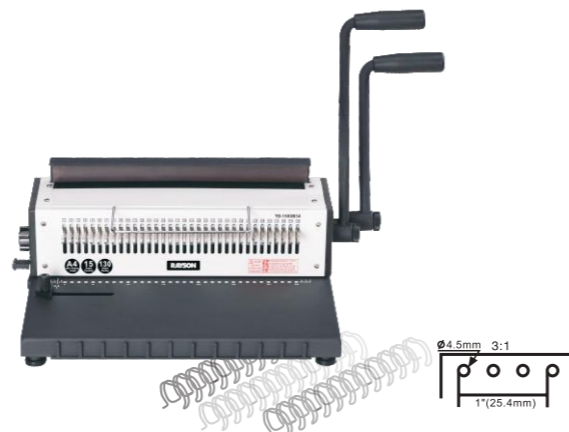

15 **A4** Double handles, easy punching up to 15 sheets per time Max.
130 Binding up to 130 sheets A4 papers Max.
140 With 34 free blades, for multi paper size

TD-200/TD-200R

F4 & Legal Size



20 **F4** Double handles, easy punching up to 20 sheets per time Max.
205 With 40 free blades & extend punching system, for any paper size
130 Binding up to 130 sheets F4 papers Max.

TD-202/TD-202R

F4 & Legal Size

2:1

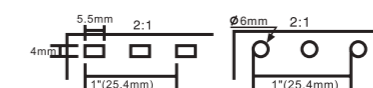

20 **F4** Double handles, easy punching up to 20 sheets per time Max.
275 With 27 free blades & extend punching system, for any paper size
200 Binding up to 200 sheets F4 papers Max.

TD-2500/TD-2500R

F4 & Legal Size



25 **F4** Double handles, easy punching up to 25 sheets per time Max.
200 Binding up to 200 sheets F4 papers Max.
140 With 40 free blades, for multi paper size

TD-205

A3



Extract Wide For A3
Binding 430mm 50 Holes

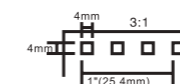

15 **A3** Double handles, easy punching up to 15 sheets per time Max.
130 Binding up to 130 sheets A3 papers Max.
140 With 40 free blades, for multi paper size

TD-205D

Extract Wide For A3
Binding 430mm 46 Square Hole,
1 R10 Half Round



Calendar

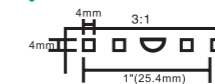

15 **A3** Double handles, easy punching up to 15 sheets per time Max.
130 Binding up to 130 sheets A3 papers Max.
145 With 49 free blades, for any paper size

ET-25/ET-25R ELECTRIC WIRE BINDER

F4 & Legal Size



25 **F4** Electric operation, easy punching up to 25 sheets per time Max.
130 Binding up to 130 sheets F4 papers Max.
140 With 40 free blades, for multi paper size



PRESS STRIP BINDER (夹条装订机)

www.bindking.com www.rayson.com.cn

JD-13+

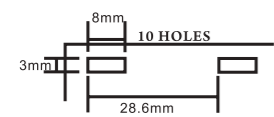

13 **A4** Punching up to 13 sheets per time Max.
10 10 holes press strip

JD-1300

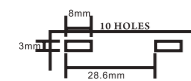

13 **A4** Punching up to 13 sheets per time Max.
10 10holes press strip

JD-2000

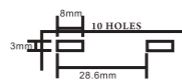

20 **A4** Punching up to 20 sheets per time Max.
10 10holes press strip



SPIRAL BINDER (单线圈装订机)

www.bindking.com www.rayson.com.cn

PD-1501

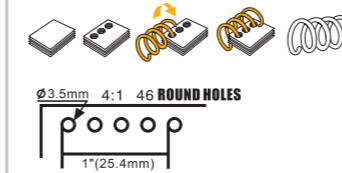

4:1 **A4** 4:1 Punching up to 15 sheets per time Max.
1 Electric binding spiral wire

PD-2000

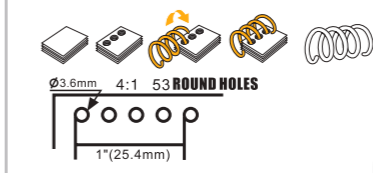

4:1 **F4** 4:1 Punching up to 15 sheets per time Max.
1 Electric binding spiral wire
1 With 53 free blades for any paper size

EP-20

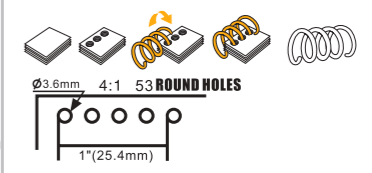

4:1 **F4** 4:1 Punching up to 25 sheets per time Max.
1 Electric binding spiral wire
1 With 53 free blades for any paper size

TDP-200

3:1 wire & spiral 2 in 1 binder

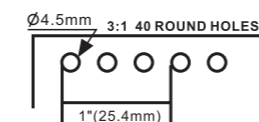

3:1 **FC** 3:1 Punching up to 20 sheets per time Max.
1 Binding spiral wire & double loop wire
1 With 40 free blades for any paper size



LAMINATOR (塑封机)

www.bindking.com www.rayson.com.cn

LM6-330 LM8-330



6 Rollers
LM6-330

8 Rollers
LM8-330

- Four hot rollers
- For A3 size
- 330mm entrance
- Laminating Speed 1500mm/min
- Max. Laminating thickness 2mm
- Ready time 5 min.
- Six hot rollers
- For A3 size
- 330mm entrance
- Laminating Speed 2300mm/min
- Max. Laminating thickness 2mm
- Ready time 5 min.

LM-230iDX LM-260iDX LM-330iDX

With 30 minute stop heating function



LM-330iDX

- For A3 size
- 330mm entrance
- Laminating Speed 500mm/min
- Max. Laminating thickness 1.2mm

LM-260iDX

- For B4 size
- 260mm entrance
- Laminating Speed 410mm/min
- Max. Laminating thickness 1mm

LM-230iDX

- For A4 size
- 230mm entrance
- Laminating Speed 410mm/min
- Max. Laminating thickness 1mm

- Four rollers
- Ready time 3-6 min.

LM-220DN LM-330DN



- Four rollers
- For A3 size
- 330mm entrance
- Laminating Speed 500mm/min
- Max. Laminating thickness 1.2mm
- Ready time 3-6 min.

Jam free

LM-330HiD



- Four rollers
- For A3 size
- 330mm entrance
- Laminating Speed 500mm/min
- Max. Laminating thickness 1.2mm
- Ready time 3-6 min.

With manual release function

LM-460iDX



- Four rollers
- For A2 size
- 460mm entrance
- Laminating Speed 500mm/min
- Max. Laminating thickness 1.2mm
- Ready time 3-6 min.

Extract wide for A2

THERMAL BINDER (热熔胶装机)



www.bindking.com www.rayson.com.cn

RD-50X



- *POWER: 100W
- *BINDING WIDE: 320mm
- *BINDING THICKNESS: 50mm
- *HEAT UP TIME: 3Mins.
- *10MIN STOP HEATING FUNCTION
- *30MINS POWER OFF FUNCTION
- *PTC HEATER

RD-50XH

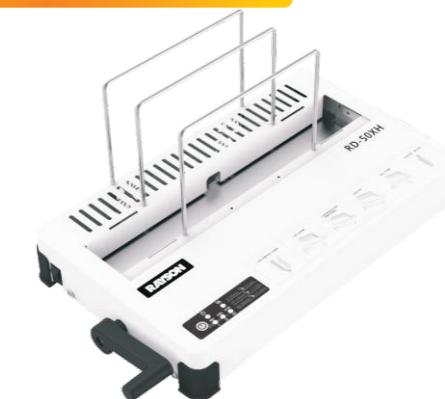

- *POWER: 100W
- *BINDING WIDE: 320mm
- *BINDING THICKNESS: 50mm
- *HEAT UP TIME: 3Mins.
- *10MIN STOP HEATING FUNCTION
- *30MINS POWER OFF FUNCTION
- *PTC HEATER
- *WITH BINDING HANDLE

CREASING MACHINE DOTTED LINE MACHINE



CREASES ON:
PLAIN PAPER
LAMINATED SHEET
COATED SHEET
PAPER BOARD

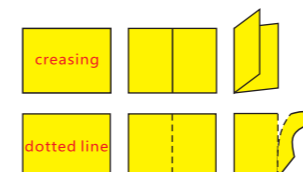

model	CM-350 creasing machine	CM-480 creasing machine	DM-350 dotted line machine
creasing	7 sheets	7 sheets	7 sheets
creasing wide(mm)	350	480	350
machine size(mm)	510x380x275	610x510x275	510x380x275
UN PKG(mm)	585x460x185	665x585x185	585x460x185
master carton(mm)	600x600x490/3pcs	680x620x620/3pcs	600x600x490/3pcs
G.W.	18kg	27kg	18kg



STAPLER (订书机)

www.bindking.com www.rayson.com.cn

SH-03

DESKTOP SADDLE STAPLER

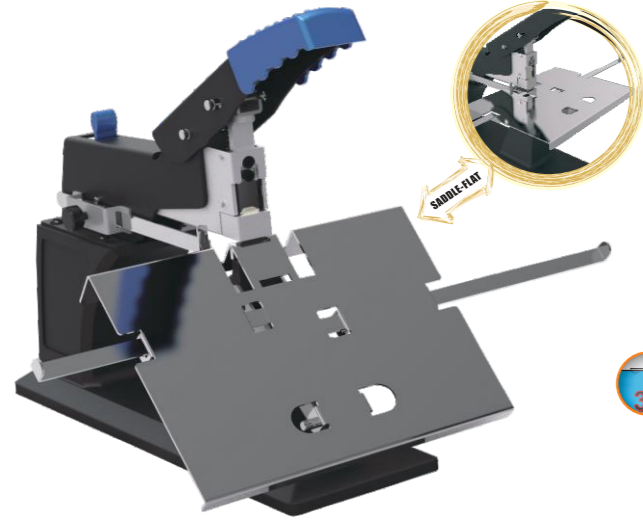

23/6	24/6
23/8	24/8
23/10	24/10



Flat/Saddle Stapling
Max. stapling thickness:6.5mm
(60 sheets 80g paper)



Using 23/6-23/10,
24/6-24/10 staples

STAPLER (订书机)



www.bindking.com www.rayson.com.cn

ST-100 & ST-100G

FLAT/SADDLE ELECTRIC STAPLER

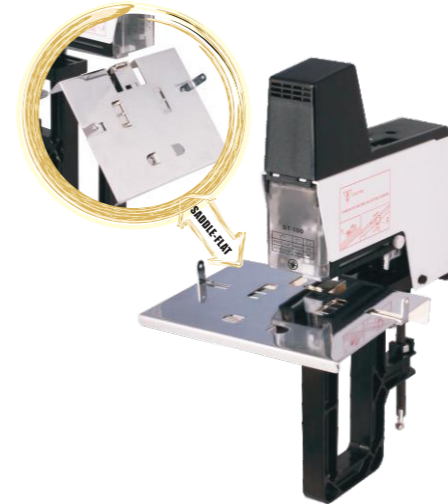

STAPLES:

MODEL:23/6,24/6	MODEL:23/8,24/8
↓	↓
STAPLING: 2-20 SHEETS (80G,2.1MM MAX.)	STAPLING: 20-40 SHEETS (80G,4.2MM MAX.)



Flat stapling 40 sheets 80g paper max.



Saddle stapling 30 sheets 80g paper max.



Load 100pcs 23/6 , 24/6 or
23/8 , 24/8 staples per time



Flat stapling 40 sheets 80g paper max.



Saddle stapling 30 sheets 80g paper max.



Load 100pcs 23/6 , 24/6 or
23/8 , 24/8 staples per time

SH-04 & SH-04G

FLAT/SADDLE STAPLER

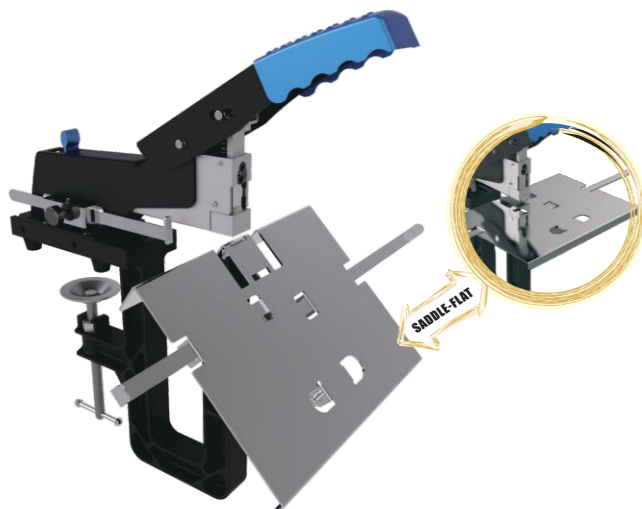

23/6	24/6
23/8	24/8
23/10	24/10



Flat/Saddle Stapling
Max. stapling thickness:6.5mm
(60 sheets 80g paper)



Using 23/6-23/10,
24/6-24/10 staples

ST-105



STAPLES:

MODEL:23/6,24/6	MODEL:23/8,24/8
↓	↓
STAPLING: 2-20 SHEETS (80G,2.1MM MAX.)	STAPLING: 20-40 SHEETS (80G,4.2MM MAX.)



Flat stapling 40 sheets 80g paper max.



Saddle stapling 30 sheets 80g paper max.



Load 100pcs 23/6 , 24/6 or
23/8 , 24/8 staples per time

ST-18

HEAVY DUTY ELECTRIC STAPLER

23/6
23/18



Flat stapling 150 sheets 80g
paper max.



Load 200pcs 23/8 - 18
staples per time



PAPER SHREDDER (碎纸机)

FEATURES (参数表)



www.bindking.com www.rayson.com.cn

www.bindking.com www.rayson.com.cn

A756

Super silent, gives comfortable operation
Intelligent circuit, auto working available
20 minutes continue working time provided
Strong cutting system, long lasting time
High level security, shred to 3.0x9mm



Cross Cut 3x9MM
Paper Capacity 5sheets
Bin Volume 16L
Noise $\leq 50\text{dB}$

Security Level	4
Shred Speed(M/MIN)	3
Entrance Wide(MM)	220
Continue Shred Time(MIN)	>20
Slot(PC)	1
Power(W)	160
Machine Size(MM)	540x250x350
Carton box(MM)	640x310x410
G.W.(KG)	10
PCS/Carton(PCS)	1

A856 A859

Super silent, gives comfortable operation
Intelligent circuit, auto working available
30 minutes continue working time provided
Strong cutting system, long lasting time
High level security, shred to 2.9x9mm



Cross Cut 2.9x9MM
Paper Capacity 6sheets
Bin Volume 18L
Noise $\leq 48\text{dB}$

Security Level	4
Shred Speed(M/MIN)	3.2
Entrance Wide(MM)	220
Continue Shred Time(MIN)	>30
Slot(PC)	1
Power(W)	130
Machine Size(MM)	550x250x350
Carton box(MM)	625x410x305
G.W.(KG)	11.5
PCS/Carton(PCS)	1

A15

Extremely powerful, shred up to 15 sheets
Strong cutting mechanism, shred CD & cards
Intelligent circuit, auto working available
30 minutes continue working time provided
Strong cutting system, long lasting time



1 Card
1 CD
Cross Cut 4x40MM
Paper Capacity 15sheets
Bin Volume 22L
Noise $\leq 49\text{dB}$

Security Level	3
Shred Speed(M/MIN)	3.2
Entrance Wide(MM)	220
Continue Shred Time(MIN)	>30
Slot(PC)	1
Power(W)	225
Machine Size(MM)	365x260x550
Carton box(MM)	410x310x640
G.W.(KG)	17.4
PCS/Carton(PCS)	1

A996

Big shredder, with 60L super big waste bin
60 minutes continue working time provided
Extremely powerful, shred up to 16 sheets
Strong cutting mechanism, shred CD & cards
Intelligent circuit, auto working available
Strong cutting system, long lasting time



1 Card
1 CD
Cross Cut 3.8x32MM
Paper Capacity 16sheets
Bin Volume 30L
Noise $\leq 60\text{dB}$

Security Level	3
Shred Speed(M/MIN)	3.5
Entrance Wide(MM)	235
Continue Shred Time(MIN)	>30
Slot(PC)	1
Power(W)	290
Machine Size(MM)	390x330x660
Carton box(MM)	495x425x740
G.W.(KG)	21.5
PCS/Carton(PCS)	1

A998

Big shredder, with 60L super big waste bin
60 minutes continue working time provided
Double mechanisms, double slots, double bins
Strong cutting mechanism, shred CD & cards
2x15mm shredding size, 10 sheets capacity
Intelligent circuit, auto working available
Strong cutting system, long lasting time



1 Card
1 CD
Cross Cut 2x15MM
Paper Capacity 10sheets
Bin Volume 30L
Noise $\leq 55\text{dB}$

Security Level	4
Shred Speed(M/MIN)	3.5
Entrance Wide(MM)	235
Continue Shred Time(MIN)	>60
Slot(PC)	2
Power(W)	345
Machine Size(MM)	390x330x660
Carton box(MM)	495x425x740
G.W.(KG)	23
PCS/Carton(PCS)	1

A999

Super security level, 0.8x5mm shred size
Strong solid steel cutter, accurate and durable
Big shredder, with 60L super big waste bin
60 minutes continue working time provided
Intelligent circuit, auto working available



Cross Cut 0.8x5.5MM
Paper Capacity 10sheets
Bin Volume 30L
Noise $\leq 50\text{dB}$

Security Level	5
Shred Speed(M/MIN)	3.5
Entrance Wide(MM)	235
Continue Shred Time(MIN)	>60
Slot(PC)	1
Power(W)	550
Machine Size(MM)	390x330x660
Carton box(MM)	495x425x740
G.W.(KG)	26
PCS/Carton(PCS)	1

C7

1 CD
Cross Cut 4x39MM
Paper Capacity 7sheets
Bin Volume 21L
Noise $\leq 55\text{dB}$



Security Level	3
Shred Speed(M/MIN)	3.0
Entrance Wide(MM)	220/125
Continue Shred Time(MIN)	>10
Slot(PC)	2
Power(W)	140
Machine Size(MM)	326x227x418
Carton box(MM)	325x228x377
G.W.(KG)	6.1
PCS/Carton(PCS)	2

C12

1 CD
Cross Cut 4x35MM
Paper Capacity 12sheets
Bin Volume 25L
Noise $\leq 60\text{dB}$



Security Level	3
Shred Speed(M/MIN)	3.0
Entrance Wide(MM)	220/125
Continue Shred Time(MIN)	>10
Slot(PC)	2
Power(W)	280
Machine Size(MM)	352x244x460
Carton box(MM)	366x234x427
G.W.(KG)	7.2
PCS/Carton(PCS)	2

A606B

Cross Cut 6.8mm
Paper Capacity 5sheets
Bin Volume 16L
Noise $\leq 70\text{dB}$



Safety Certificate	CE
Shred Capacity	5 sheets strip cut
Security Level	2
Shred Size(MM)	6.8mm
Working Width(MM)	220
Bin Volume(L)	10
Shredder Speed(M/MIN)	3.8
Unit Size(MM)	300x162x280
G.W.(KG)	1.6

A106P

1 Card
1 CD
Cross Cut 6mm strip cut
Paper Capacity 7sheets
Bin Volume 16L
Noise $\leq 70\text{dB}$



Safety Certificate	CE
Shred Capacity	7 sheets strip cut
Rated Credit Card Capacity	1 Credit Card & 1 CD
Security Level	2
Shred Size(MM)	6.0mm Strip Cut
Working Width(MM)	220
Bin Volume(L)	10
Shredder Speed(M/MIN)	3.0
Unit Size(MM)	300x162x289
G.W.(KG)	2.6

COMB BINDING MACHINE

MODEL	punching 80g/70g A4 (sheets)	binding (sheets)	holes size (mm)	hole qty (mm)	free pins (pcs)	margin (mm)	size (mm)	inner box (mm)	carton (mm)	G.W. (kg)	pcs/carton	20'/40' FCL (PCS)
SD-1201	12/15	200	3X8	21	NO	3-6	395X210X280	415X185X275	775X430X295	25.4	4	1268/2552
SD-1501	15/18	200	3X8	21	NO	3-6	395X260X330	415X190X310	785X430X335	27.9	4	1112/2160
SD-1501A21	15/18	200	3X8	21	21	3-6	395X260X330	415X190X310	785X430X335	27.9	4	1112/2160
W-25	15/20	220	3X8	21	3	3,5,7	500X320X400	460X250X380	538X487X420	19.8	2	542/1029
SD-2011B21	20/25	400	3X8	21	21	3,6,9	500X320X400	460X250X380	538X487X420	24.6	2	542/1029
SD-2501B21	25/30	400	3X8	21	21	3,6,9	500X490X450	456X270X446	555X465X460	28.8	2	520/1000
SD-2021B24	20/25(F4)	400	3X8	24	24	3,6,9	540X410X390	530X465X210	545X495X240	19.9	1	396/864
EB-20	18/23	400	3X8	21	21	3,5,7	420X270X180	425X320X245	455X340X525	24.8	2	754/1532
EB-30	30/35	400	3X8	21	21	3,6,9	480X400X290	460X450X285	480X475X325	24.3	1	336/700

WIRE BINDING MACHINE

MODEL	punching 80g/70g A4 (sheets)	binding (sheets)	holes size (mm)	hole qty (mm)	free pins (pcs)	margin (mm)	size (mm)	inner box (mm)	carton (mm)	G.W. (kg)	pcs/carton	20'/40' FCL (PCS)
ET-25	25/28	130	□4X4 ○4.5	40	40	2.5, 4.5, 6.5	580X410X510	463X450X285	480X475X325	27	1	336/700
TD-1200	12/15	120	□4X4 ○4.5	34	NO	3, 5, 7	530X220X290	468X200X260	485X450X290	16.2	2	1038/2076
TD-1200R	12/15	120	□4X4	34	NO	2.5, 4.5, 6.5	420X230X370	430X190X290	750X440X320	21.1	4	1144/2304
TD-1500	15/18	130	□4X4 ○4.5	34	NO	3, 5, 7	530X260X350	470X200X310	485X425X335	19.9	2	900/1790
TD-1500R	15/18	130	□4X4 ○4.5	34	10	3, 5, 7	530X260X350	470X200X310	485X425X335	19.4	2	900/1790
TD-1500B10	15/18	130	□4X4 ○4.5	34	10	3, 5, 7	530X260X350	470X200X310	485X425X335	19.4	2	900/1790
TD-1500B10R	15/18	130	□4X4 ○4.5	34	10	3, 5, 7	530X260X350	470X200X310	485X425X335	19.4	2	900/1790
TD-1500B34	15/18	130	□4X4 ○4.5	34	34	3, 5, 7	530X260X350	470X200X310	485X425X335	20.7	2	900/1790
TD-1500B34R	15/18	130	□4X4 ○4.5	34	34	3, 5, 7	530X260X350	470X200X310	485X425X335	20.7	2	900/1790
TD-200	20/23	130	□4X4 ○4.5	40	40	2.5, 4.5, 6.5	580x340x520	510x410x275	530x430x300	18.9	1	451/902
TD-200R	20/23	130	□4X4 ○4.5	40	40	2.5, 4.5, 6.5	580x340x520	510x410x275	530x430x300	18.9	1	451/902
TD-202	20/23	200	□4X5.5 ○6	27	27	2.5, 4.5, 6.5	580x340x520	510x410x275	530x430x300	18.5	1	451/902
TD-202R	20/23	200	□4X5.5 ○6	27	27	2.5, 4.5, 6.5	580x340x520	510x410x275	530x430x300	18.5	1	451/902
TD-205	15/18	130	□4X4	50	40	2.5, 4.5, 6.5	680X340X510	610X430X285	630X440X300	23.5	1	356/735
TD-205D	15/18	130	□4X4	46 square hole, 1 R10 half round	49	2.5, 4.5, 6.5	680X340X510	610X430X285	630X440X300	24.1	1	356/735
TD-2500	25/28	200	□4X4 ○4.5	40	40	2.5, 5, 7, 9	580x410X510	500x315X470	535X345X495	20.5	1	332/672
TD-2500R	25/28	200	□4X4 ○4.5	40	40	2.5, 5, 7, 9	580x410X510	500x315X470	535X345X495	20.5	1	332/672

SPIRAL BINDING MACHINE

MODEL	punching 80g/70g A4 (sheets)	binding (sheets)	holes size (mm)	hole qty (mm)	free pins (pcs)	margin (mm)	size (mm)	inner box (mm)	carton (mm)	G.W. (kg)	pcs/carton	20'/40' FCL (PCS)
PD-1501	15/18	UP TO RING	Ø3.5	46	NO	3,5,7	465X260X360	470X325X200	490X335X485	16.5	2	768/1522
JD-1300	13/16	UP TO RING	3X8	10	NO	5.5	365X210X335	415X185X275	775X430X295	22.1	4	1268/2552
TDP-200	20/25	UP TO RING	Ø3.6	40	40	2.5,4.5,6.5	580X340X520	510X410X275	525X425X300	18.7	1	451/902
PD-2000	15/20	UP TO RING	Ø3.6	53	53	2.5,4.5,6.5	600X430X510	500X315X470	535X345X490	16.5	1	332/683
EP-20	20/25	UP TO RING	Ø3.6	53	53	2.5,4.5,6.5	580X410X510	463X450X285	485X475X325	22.3	1	384/800

LAMINATOR

MODEL	LAMINATING WIDTH (mm)	LAMINATING THICKNESS MAX. (mm)	MAX TEMP (sheets)	ROLLERS (pcs)	COLD LAMINATING FUNCTION	REVERSE	worm up (min)	POWER (W)	MACHINE SIZE (mm)	CARTON (mm)	G.W. (kg)	pcs/carton	20'/40' FCL (PCS)
LM-330	330	1.2	180	4	●	●	3-6	600	510X200X110	575X255X335	15.5	2	1240/2450
LM-22	230	0.6	120	2	●	●	3-6	200	350x155x82	395x345x395	9.5	6	3204/6780
LM-32	330	0.6	125	2	●	●	3-6	260	429X105X90	468X447X263	11.5	6	3402/6798
LM-330iDX	330	1.2	180	4	●	●	3-6	600	530x210x110	600x300x285	14.1	2	1144/2268
LM-230iD	230	1	180	4	●	●	3-6	400	430X210X110	605X500X285	8.0	4	1440/2852
LM-330iD	330	1.2	180	4	●	●	3-6	600	530x210x110	600x300x285	14.1	2	1144/2268
LM-460iD	460	1.2	180	4	●	●	3-6	700	645x210x110	720x275x345	19.4	2	496/1762
LM6-330	330	2	170	6	●	●	5	1000	520X300X150	635X415X275	19.1	1	432/835
LM8-330	330	2	170	8	●	●	5	1500	520x300x150	635x415x275	21.4	1	432/835
LM-220DN	220	1	180	4	●	●	3-6	500	400X200X115	470X320X265	13.3	2	1550/3138
LM-330DN	330	1.2	180	4	●	●	3-6	600	510X200X110	585X335X290	15.1	2	1100/2164

STAPLE

MODEL	staple	binding (sheets)	size (mm)	inner box (mm)	carton (mm)	G.W. (kg)	pcs/carton	20'/40' FCL (PCS)
ST-105	23/6,23/8 24/6,24/8	40	370x200x340	400x145x370	425x325x415	11.5	2	1064/2102
ST-100	23/6,23/8 24/6,24/8	40	340x200x420	480x300x135	500x310x285	12.1	2	1392/2786
ST-100G	23/6,23/8 24/6,24/8	40	600x200x420	480x300x135	505x310x330	13	1set	595/1212
ST-66-2	23/6,23/8	40	340x270x410	375x295x430	615x370x440	18.8	2	610/1248
ST-18	23/8-23/18	150	490x260x345	530x280x360	530x280x360	27.5	1	578/1154
SH-03	23/6-23/10 24/6-24/10	60	370x200x340	410x160x290	575x430x485	20.1	6	1554/3066
SH-04	23/6-23/10 24/6-24/10	60	300x200x49					