



Eco-Pack

**Originating from Nature
Returning to Nature**

Liaoning Kunze Industrial Group Co.,Ltd
Liaoning Kunze Import and Export Trading Co.,Ltd



Web



CONTENT

1

About Sugarcane pulp packaging/tableware

2

Introduction of Factory

3

Quality Control



Sugarcane Pulp Tableware



What is it ?

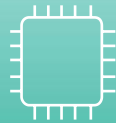

Features



Comparison

What is Sugarcane Pulp Tableware

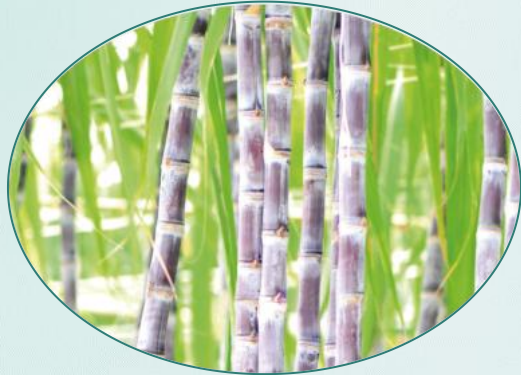

Sugarcane is pressed to produce sucrose (the raw material of sugar) and bagasse. The bagasse is fermented and cooked at high temperature to become plant fiber, which can be used to make biodegradable and environmental friendly bagasse tableware. The containers and the food that contained are made from organic material, so they can be fermented into organic fertilizer and returned to the farmland, thereby forming a complete ecological chain.



Features of Sugarcane Pulp Tableware

I CAN



Comparison With Substitutable Products

PLA

Made from corn; Short of supply usually;
Can not compost in the ocean.

PP

Petroleum base; Not compostable.

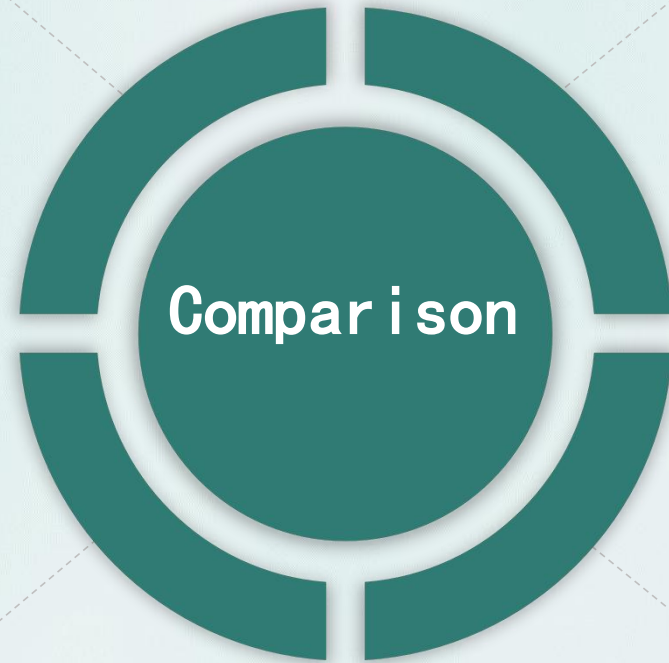

PET

Petroleum base; Not compostable;
Can not be used in Micro Oven.

EPS

Petroleum base; Not compostable;
Can not be used in Micro Oven; Not
safe for hot food.



About Kunze



History of KZ

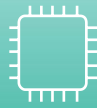

**Products and
service**



**Production
and R&D**

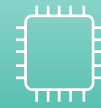

**Advanced
Technologies**



Future Plan

History of Kunze

**Year
2016**

KZ team engaged in packaging and printing industry, specialized in paper packaging.

**Year
2019**

Established Kunze trading company to export paper packaging and import raw paper from overseas.

**Year
2020**

Partnership with biodegradable pulp packaging industry and win another development step .

**Year
2022**

Won the contract of 3-year with Airline New Zealand to supply bagasse tableware. Which is a milestone for us.

**Year
2023**

With intensive co-operation with manufacturing plant, we are playing an important role in supplying R-PET,PLA, Bamboo packaging to the worldwide.

About Bagasse Factory



Location:

Laibin City, Guangxi Province

Scale:

Plant: 83,473 square meter

Workshop: 43,900 square meter

Warehouse: 5,000

Personnel:

Management: 70 persons

R&D: 89 persons

QA: 49 persons

Worker: 621 persons

Products and service

Customized items

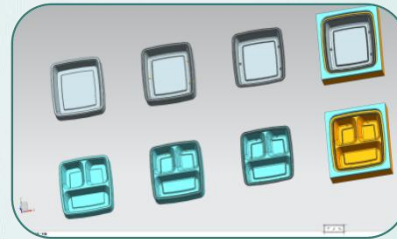

Regular items for
food packaging

Products and
Service



Moulding design
and producing



R&D with partners

Production and R&D

Production



Self-designed fully automatic production lines ensure the high quality products.

Daily output for one machine is 1 ton. Phase 1 plant can provide 240*40HQ monthly output.

Guangxi factory was designed and built with high standard. BRC AA grade certified.

Production and R&D



Our in-house mold workshop provides better intellectual property protection.



Independent design ability, helps us in the leading position in this field.



Can provide customized design.



With more than 15-year' s experience technical team, can provide powerful technique support.

Advanced Techniques

Trimming free technique

Before trimming



Trimmed products



Trimming free products



Advanced Techniques

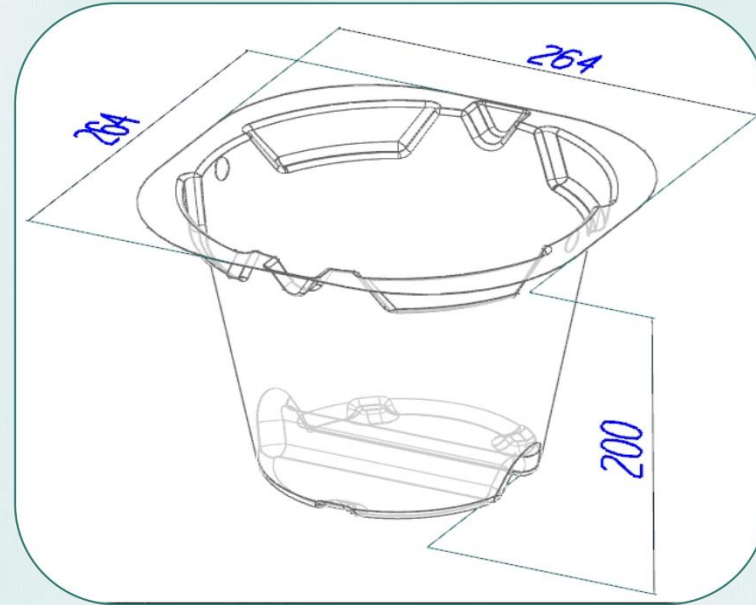

High draft technology

Once, the maximum draft height can be done in this industry was 90mm, in the summer of 2018, we broke through to 200mm, as shown in the following kitchen waste bins, and it's waterproof, oil-proof, vinegar-proof, bearing 5 kg...

Advanced Techniques



- **Anti-sticking**
- **Better performance in Microwave oven use**
- **Better performance in freezer**

Quality control process

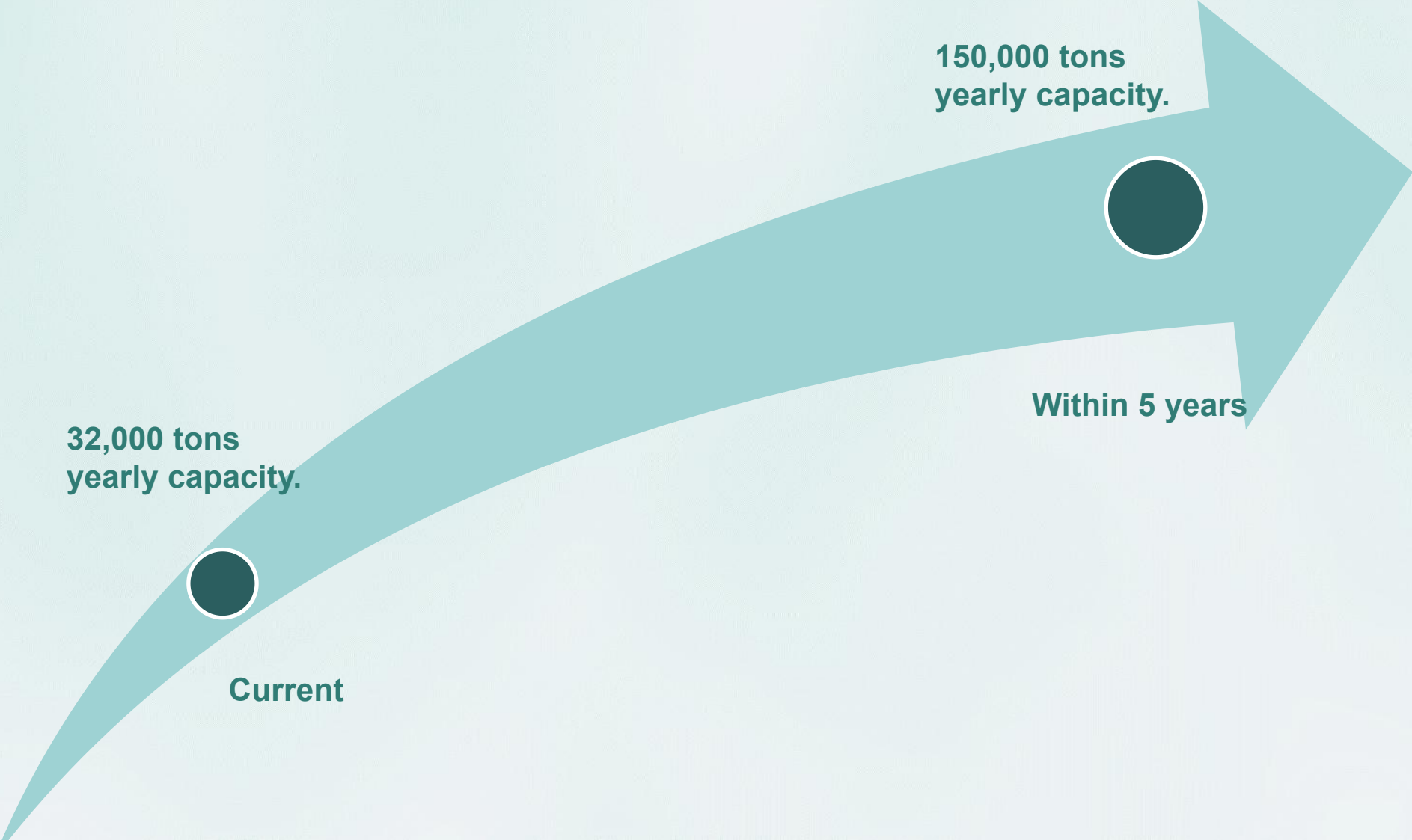



Quality control in factory



**Quality control
process**

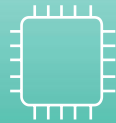

**Intelligent
Equipment**



Certificates

Quality control process

Strict quality control, ensure to provide high quality products.

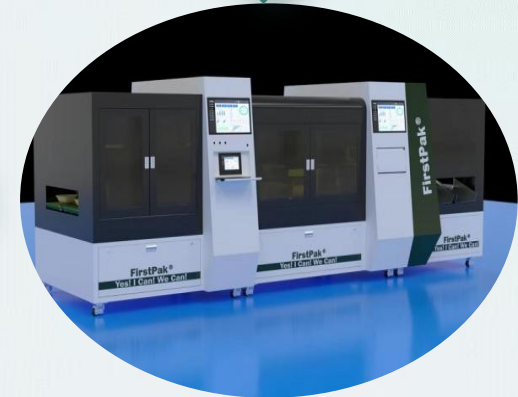

Intelligent Equipment



Intellectualized Control of the pulp, including the additives and the concentration of the pulp. It can avoid the human error.



Intelligent forming machines and keep the consistency of production parameters.



Intelligent inspection machines can make the quality More consistent.

Our Client

Best Prices
eBPak

Huhtamaki

Aēsop®

**Loblaw
Companies
Limited**

AIR NEW ZEALAND 

Certificates and reports.

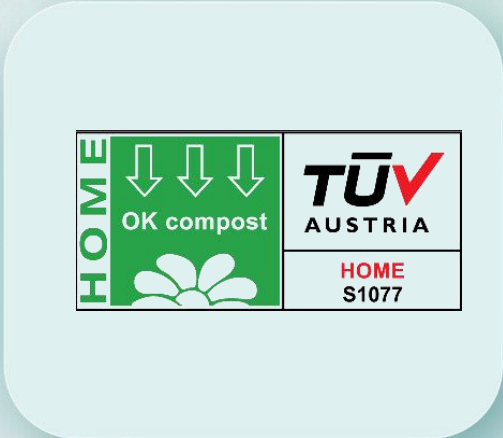



KUNZE 坤泽

 PulPak

THANKS

E-mail: eco-pack@eco-pack.com
Web: www.eco-pack.com



Web