



FCC TEST REPORT

FCC ID:2BLNX-GT-01

Report Number.....: **ZKT-24092512269E**

Date of Test..... Sept. 25, 2024 to Oct. 23, 2024

Date of issue.....: Oct. 23, 2024

Total number of pages..... 35

Test Result: PASS

Testing Laboratory.....: Shenzhen ZKT Technology Co., Ltd.

Address: 1/F, No. 101, Building B, No. 6, Tangwei Community Industrial Avenue, Fuhai Street, Bao'an District, Shenzhen, China

Applicant's name: MDC ELECTRONICS Co.,Limited

Address: Room603,Business Building D,TongAn Park,GuShu, XiXiang Bao'an District,ShenZhen,China,518102

Manufacturer's name: MDC ELECTRONICS Co.,Limited

Address: Room603,Business Building D,TongAn Park,GuShu, XiXiang Bao'an District,ShenZhen,China,518102

Test specification:

Standard.....: FCC CFR Title 47 Part 15 Subpart C Section 15.249
ANSI C63.10:2013

Test procedure.....: /

Non-standard test method: N/A

Test Report Form No.....: /

Test Report Form(s) Originator.....: ZKT Testing

Master TRF: Dated: 2020-01-06

This device described above has been tested by ZKT, and the test results show that the equipment under test (EUT) is in compliance with the FCC requirements. And it is applicable only to the tested sample identified in the report.

This report shall not be reproduced except in full, without the written approval of ZKT, this document may be altered or revised by ZKT, personal only, and shall be noted in the revision of the document.

Product name.....: 5.8G Audio Transceiver

Trademark: N/A

Model/Type reference.....: GT-01

GT-02, GT-03, GT-04, GT-05, AC-01, AC-02, AC-03, AC-04, AC-05,
RX-01, RX-02, RX-03, RX-04, RX-05, TC-01, TC-02, TC-03, TC-04,
TC-05

Ratings.....: Input:DC 5V



Testing procedure and testing location:

Testing Laboratory.....: **Shenzhen ZKT Technology Co., Ltd.**

Address.....: 1/F, No. 101, Building B, No. 6, Tangwei Community Industrial Avenue, Fuhai Street, Bao'an District, Shenzhen, China

Tested by (name + signature).....: Jim Liu

Reviewer (name + signature).....: Jackson Fang

Approved (name + signature).....: Lake Xie





Table of Contents

	Page
1. VERSION	4
2. TEST SUMMARY	5
2.1 TEST FACILITY	6
2.2 MEASUREMENT UNCERTAINTY	6
3.1 GENERAL DESCRIPTION OF EUT	7
3.2 Test Setup Configuration	9
3.3 Support Equipment	9
4. EMC EMISSION TEST	13
4.1 Conducted emissions	13
4.1.1 POWER LINE CONDUCTED EMISSION Limits	13
4.1.2 TEST PROCEDURE	13
4.1.3 DEVIATION FROM TEST STANDARD	13
4.1.4 TEST SETUP	14
4.1.5 EUT OPERATING CONDITIONS	14
4.1.6 Test Result	15
4.2 Radiated emissions	17
4.2.1 Radiated Emission Limits	17
4.2.2 TEST PROCEDURE	18
4.2.3 DEVIATION FROM TEST STANDARD	18
4.2.4 TEST SETUP	18
4.2.5 EUT OPERATING CONDITIONS	19
4.2.6 TEST RESULTS	19
5. RADIATED BAND EMISSION MEASUREMENT	25
5.1 Test Requirement:	25
5.2 TEST PROCEDURE	25
5.3 DEVIATION FROM TEST STANDARD	26
5.4 TEST SETUP	26
5.5 EUT OPERATING CONDITIONS	26
5.6 TEST RESULT	27
6. 20DB BANDWIDTH	31
6.1 Test Setup	31
6.2 Limit	31
6.3 Test procedure	31
6.4 DEVIATION FROM STANDARD	31
6.5 Test Result	31
7. ANTENNA REQUIREMENT	34
8. TEST SETUP PHOTO	35
9. EUT CONSTRUCTIONAL DETAILS	35



1. VERSION

Report No.	Version	Description	Approved
ZKT-24092512269E	Rev.01	Initial issue of report	Oct. 23, 2024

深圳魔力声学有限公司



2. TEST SUMMARY

Test procedures according to the technical standards:

FCC Part15 (15.249) , Subpart C			
Standard Section	Test Item	Result	Remark
15.203	Antenna Requirement	PASS	
15.207	AC Power Line Conducted Emission	PASS	
15.215 (c)	20dB Occupied Bandwidth	PASS	
15.209/15.249	Radiated Emission and Fundamental	PASS	
15.205/15.209	Restricted Band	PASS	

NOTE:

(1) "N/A" denotes test is not applicable in this Test Report



2.1 TEST FACILITY

Shenzhen ZKT Technology Co., Ltd.
Add. : 1/F, No. 101, Building B, No. 6, Tangwei Community Industrial Avenue, Fuhai Street, Bao'an District, Shenzhen, China

FCC Test Firm Registration Number: 692225
Designation Number: CN1299
IC Registered No.: 27033
CAB identifier: CN0110

2.2 MEASUREMENT UNCERTAINTY

The reported uncertainty of measurement $y \pm U$, where expanded uncertainty U is based on a standard uncertainty multiplied by a coverage factor of $k=2$, providing a level of confidence of approximately 95 %.

No.	Item	Uncertainty
1	3m chamber Radiated spurious emission(9KHz-30MHz)	U=4.5dB
2	3m chamber Radiated spurious emission(30MHz-1GHz)	U=4.8dB
3	3m chamber Radiated spurious emission(1GHz-6GHz)	U=4.9dB
4	3m chamber Radiated spurious emission(6GHz-40GHz)	U=5.0dB
5	Conducted disturbance	U=3.2dB
6	RF Band Edge	U=1.68dB
7	RF Occupied Bandwidth	U=1.8MHz
8	humidity uncertainty	U=5.3%
9	Temperature uncertainty	U=0.59°C



3. GENERAL INFORMATION

3.1 GENERAL DESCRIPTION OF EUT

Product Name:	5.8G Audio Transceiver
Model No.:	GT-01
Model Different.:	Only for different model name
Serial No.:	GT-02, GT-03, GT-04, GT-05, AC-01, AC-02, AC-03, AC-04, AC-05, RX-01, RX-02, RX-03, RX-04, RX-05, TC-01, TC-02, TC-03, TC-04, TC-05
Sample(s) Status:	Engineer sample
Channel numbers:	120
Operation Frequency:	5730MHz~5850MHz
Modulation technology:	GFSK
Antenna Type:	External antenna
Antenna gain:	3dBi
Power supply:	Input:DC 5V
AC/DC Adapter:	N/A
AC/DC Adapter Mode:	N/A



Channel	Frequency (MHz)	Channel	Frequency (MHz)	Channel	Frequency (MHz)	Channel	Frequency (MHz)	Channel	Frequency (MHz)
0	5730	26	5756	52	5782	78	5808	104	5834
1	5731	27	5757	53	5783	79	5809	105	5835
2	5732	28	5758	54	5784	80	5810	106	5836
3	5733	29	5759	55	5785	81	5811	107	5837
4	5734	30	5760	56	5786	82	5812	108	5838
5	5735	31	5761	57	5787	83	5813	109	5839
6	5736	32	5762	58	5788	84	5814	110	5840
7	5737	33	5763	59	5789	85	5815	111	5841
8	5738	34	5764	60	5790	86	5816	112	5842
9	5739	35	5765	61	5791	87	5817	113	5843
10	5740	36	5766	62	5792	88	5818	114	5844
11	5741	37	5767	63	5793	89	5819	115	5845
12	5742	38	5768	64	5794	90	5820	116	5846
13	5743	39	5769	65	5795	91	5821	117	5847
14	5744	40	5770	66	5796	92	5822	118	5848
15	5745	41	5771	67	5797	93	5823	119	5849
16	5746	42	5772	68	5798	94	5824	120	5850
17	5747	43	5773	69	5799	95	5825		
18	5748	44	5774	70	5800	96	5826		
19	5749	45	5775	71	5801	97	5827		
20	5750	46	5776	72	5802	98	5828		
21	5751	47	5777	73	5803	99	5829		
22	5752	48	5778	74	5804	100	5830		
23	5753	49	5779	75	5805	101	5831		
24	5754	50	5780	76	5806	102	5832		
25	5755	51	5781	77	5807	103	5833		

Note:

In section 15.31(m), regards to the operating frequency range over 10 MHz, the Lowest frequency, the middle frequency, and the highest frequency of channel were selected to perform the test, and the selected channel see below:

Test channel	Frequency
The lowest channel	5730MHz
The middle channel	5790MHz
The Highest channel	5850MHz



3.2 Test Setup Configuration

Operation of EUT during Conducted and Radiation testing:



Operation of EUT during RF Conducted testing:

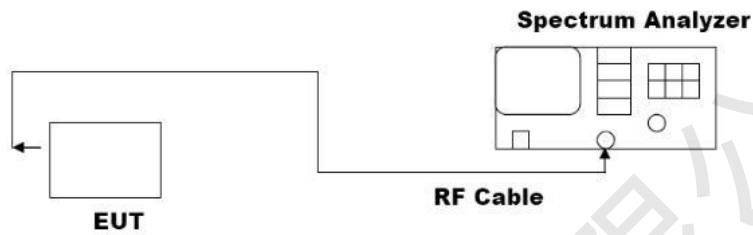

3.3 Support Equipment

The EUT has been tested as an independent unit together with other necessary accessories or support units. The following support units or accessories were used to form a representative test configuration during the tests.

Item	Equipment	Mfr/Brand	Model/Type No.	Series No.	Note
E-1	5.8G Audio Transceiver	N/A	GT-01	See page 7	EUT
A-1	Adapter	HUAWEI	HW-050100B3W	N/A	Auxiliary

Item	Shielded Type	Ferrite Core	Length	Note
C1	NO	NO	1.0M	Car Charger

Note:

- (1) The support equipment was authorized by Declaration of Confirmation.
- (2) For detachable type I/O cable should be specified the length in cm in 『Length』 column.



3.4 Test Mode

Transmitting mode	Keep the EUT in continuously transmitting mode.
Remark: During the test, the test voltage was tuned from 85% to 115% of the nominal rated supply voltage, and found that the worst case was under the nominal rated supply condition. So the report just shows that condition's data.	
Test Software	Secure CRT Portable
Power level setup	<0dBm

深圳魔力声学有限公司



3.5 EQUIPMENTS LIST FOR ALL TEST ITEMS

Conducted emissions Test

Item	Kind of Equipment	Manufacturer	Type No.	Serial No.	Firmware Version	Last calibration	Calibrated until
1	LISN	R&S	ENV216	101471	N/A	Nov. 14, 2023	Nov. 13, 2024
2	LISN	CYBERTEK	EM5040A	E1850400149	N/A	Nov. 02, 2023	Nov. 01, 2024
3	Test Cable	N/A	C-01	N/A	N/A	Nov. 02, 2023	Nov. 01, 2024
4	Test Cable	N/A	C-02	N/A	N/A	Nov. 02, 2023	Nov. 01, 2024
5	Test Cable	N/A	C-03	N/A	N/A	Nov. 02, 2023	Nov. 01, 2024
6	EMI Test Receiver	R&S	ESCI3	101393	4.42 SP3	Nov. 02, 2023	Nov. 01, 2024
7	Triple-Loop Antenna	N/A	RF300	N/A	N/A	Nov. 02, 2023	Nov. 01, 2024
8	Absorbing Clamp	DZ	ZN23201	15034	N/A	Nov. 07, 2023	Nov. 06, 2024
9	EMC Software	Frad	EZ-EMC	Ver.EMC-CON 3A1.1	N/A	\	\



Radiation emissions & Radio Test equipment

Item	Equipment	Manufacturer	Type No.	Serial No.	Firmware Version	Last calibration	Calibrated until
1	Spectrum Analyzer (9kHz-26.5GHz)	KEYSIGHT	9020A	MY55370835	A.17.05	Nov. 02, 2023	Nov. 01, 2024
2	Spectrum Analyzer (10kHz-39.9GHz)	R&S	FSV40-N	100363	1.71 SP2	Nov. 02, 2023	Nov. 01, 2024
3	EMI Test Receiver (9kHz-7GHz)	R&S	ESCI7	100969	4.32	Nov. 02, 2023	Nov. 01, 2024
4	Bilog Antenna (30MHz-1500MHz)	Schwarzbeck	VULB9168	N/A	N/A	Nov. 13, 2023	Nov. 12, 2024
5	Horn Antenna (1GHz-18GHz)	Agilent	AH-118	071145	N/A	Nov. 13, 2023	Nov. 12, 2024
6	Horn Antenna (15GHz-40GHz)	A.H.System	SAS-574	588	N/A	Nov. 13, 2023	Nov. 12, 2024
7	Loop Antenna	TESEQ	HLA6121	58357	N/A	Nov. 16, 2023	Nov. 15, 2024
8	Amplifier (30-1000MHz)	EM Electronics	EM330 Amplifier	60747	N/A	Nov. 02, 2023	Nov. 01, 2024
9	Amplifier (1GHz-26.5GHz)	HuiPu	8449B	3008A00315	N/A	Nov. 02, 2023	Nov. 01, 2024
10	Amplifier (500MHz-40GHz)	QuanJuDa	DLE-161	097	N/A	Nov. 02, 2023	Nov. 01, 2024
11	Test Cable	N/A	R-01	N/A	N/A	Nov. 02, 2023	Nov. 01, 2024
12	Test Cable	N/A	R-02	N/A	N/A	Nov. 02, 2023	Nov. 01, 2024
13	Test Cable	N/A	R-03	N/A	N/A	Nov. 02, 2023	Nov. 01, 2024
14	Test Cable	N/A	RF-01	N/A	N/A	Nov. 02, 2023	Nov. 01, 2024
15	Test Cable	N/A	RF-02	N/A	N/A	Nov. 02, 2023	Nov. 01, 2024
16	Test Cable	N/A	RF-03	N/A	N/A	Nov. 02, 2023	Nov. 01, 2024
17	ESG Signal Generator	Agilent	E4421B	N/A	B.03.84	Nov. 02, 2023	Nov. 01, 2024
18	Signal Generator	Agilent	N5182A	N/A	A.01.87	Nov. 02, 2023	Nov. 01, 2024
19	Magnetic Field Probe Tester	Narda	ELT-400	0-0344	N/A	Nov. 16, 2023	Nov. 15, 2024
20	Wideband Radio Communication Test	R&S	CMW500	106504	V 3.7.22	Nov. 02, 2023	Nov. 01, 2024
21	Power Meter	KEYSIGHT	N1912A P	N/A	A.05.00	Nov. 02, 2023	Nov. 01, 2024
22	D.C. Power Supply	LongWei	TPR-6405D	N/A	N/A	\	\
23	EMC Software	Frad	EZ-EMC	Ver.EMC-CO N 3A1.1	N/A	\	\
24	RF Software	MW	MTS8310	V2.0.0.0	N/A	\	\
25	Turntable	MF	MF-7802BS	N/A	N/A	\	\
26	Antenna tower	MF	MF-7802BS	N/A	N/A	\	\



4. EMC EMISSION TEST

4.1 Conducted emissions

Test Requirement:	FCC Part15 C Section 15.207
Test Method:	ANSI C63.10:2013
Test Frequency Range:	150KHz to 30MHz
Receiver setup:	RBW=9KHz, VBW=30KHz, Sweep time=auto

4.1.1 POWER LINE CONDUCTED EMISSION Limits

FREQUENCY (MHz)	Limit (dBuV)		Standard
	Quasi-peak	Average	
0.15 -0.5	66 - 56 *	56 - 46 *	FCC
0.50 -5.0	56.00	46.00	FCC
5.0 -30.0	60.00	50.00	FCC

Note:

(1) *Decreases with the logarithm of the frequency.

4.1.2 TEST PROCEDURE

- a. The EUT was placed 0.8 meters from the horizontal ground plane with EUT being connected to the power mains through a line impedance stabilization network (LISN). All other support equipments powered from additional LISN(s). The LISN provide 50 Ohm/ 50uH of coupling impedance for the measuring instrument.
- b. Interconnecting cables that hang closer than 40 cm to the ground plane shall be folded back and forth in the center forming a bundle 30 to 40 cm long.
- c. I/O cables that are not connected to a peripheral shall be bundled in the center. The end of the cable may be terminated, if required, using the correct terminating impedance. The overall length shall not exceed 1 m.
- d. LISN at least 80 cm from nearest part of EUT chassis.
- e. For the actual test configuration, please refer to the related Item –EUT Test Photos.

4.1.3 DEVIATION FROM TEST STANDARD

No deviation



4.1.4 TEST SETUP

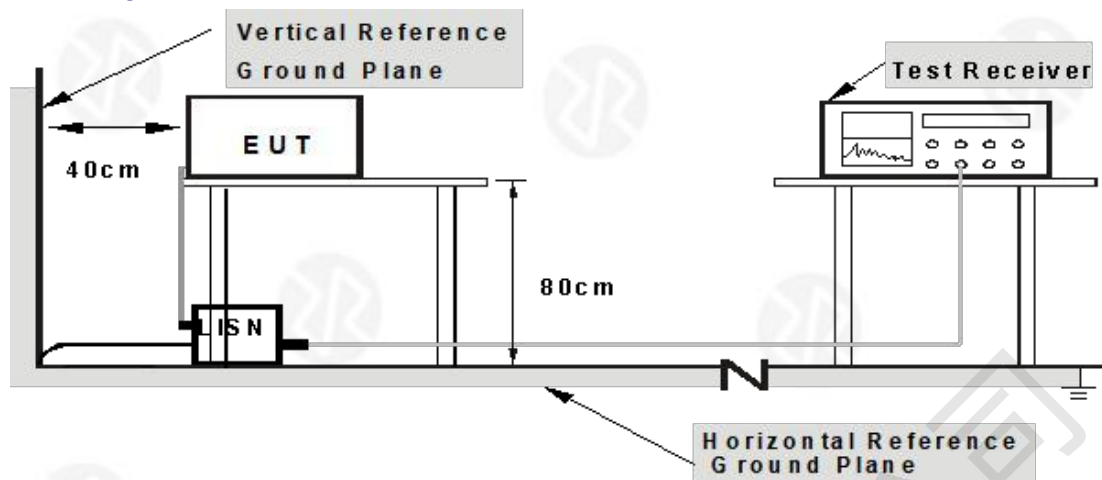

- Note:**
- 1.Support units were connected to second LISN.
 - 2.Both of LISNs (AMN) are 80 cm from EUT and at least 80 from other units and other metal planes

4.1.5 EUT OPERATING CONDITIONS

The EUT was configured for testing in a typical fashion (as a customer would normally use it). The EUT has been programmed to continuously transmit during test. This operating condition was tested and used to collect the included data.



4.1.6 Test Result

Temperature:	26°C	Relative Humidity:	54%
Pressure:	101kPa	Phase :	L
Test Voltage :	AC 120V/60Hz	Test Channel :	5730MHz

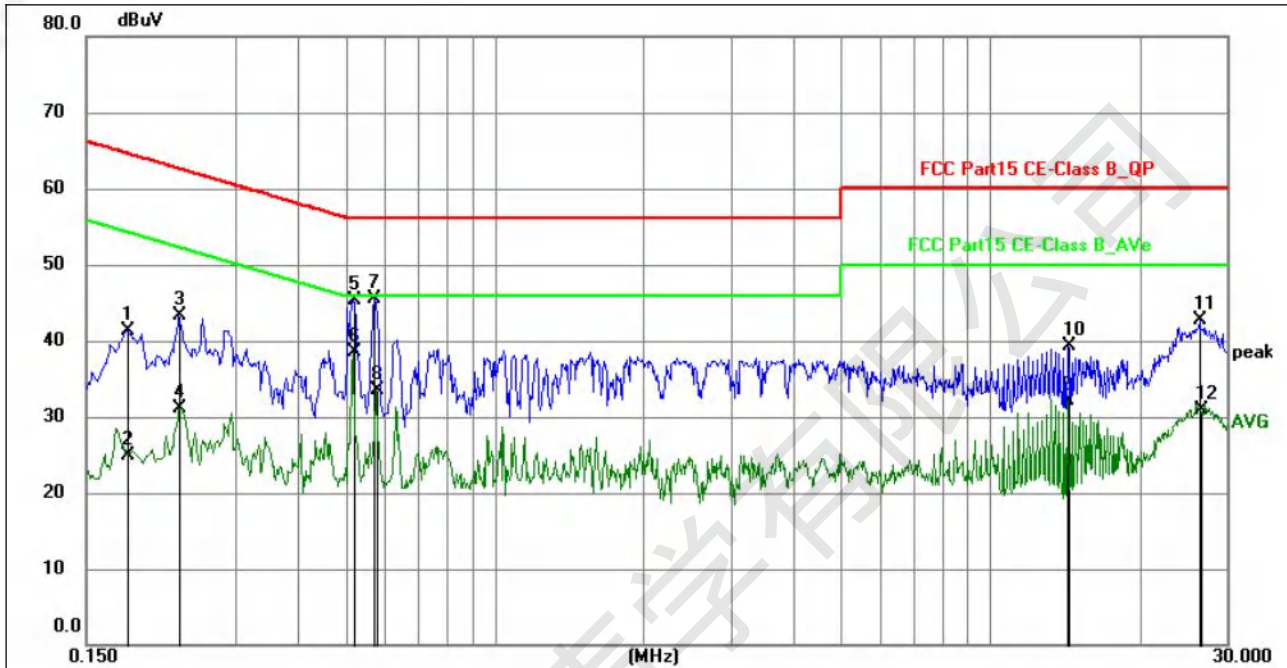

No.	Frequency (MHz)	Reading (dBuV)	Factor (dB)	Level (dBuV)	Limit (dBuV)	Margin (dB)	Detector	P/F	Remark
1	0.1814	20.42	20.97	41.39	64.42	-23.03	QP	P	
2	0.1814	4.03	20.97	25.00	54.42	-29.42	AVG	P	
3	0.2310	22.22	21.02	43.24	62.41	-19.17	QP	P	
4	0.2310	10.18	21.02	31.20	52.41	-21.21	AVG	P	
5	0.5190	24.43	20.83	45.26	56.00	-10.74	QP	P	
6	0.5190	17.61	20.83	38.44	46.00	-7.56	AVG	P	
7	0.5726	24.67	20.83	45.50	56.00	-10.50	QP	P	
8	0.5774	12.65	20.83	33.48	46.00	-12.52	AVG	P	
9	14.3520	9.27	22.77	32.04	50.00	-17.96	AVG	P	
10	14.3655	16.63	22.77	39.40	60.00	-20.60	QP	P	
11	26.5560	17.98	24.77	42.75	60.00	-17.25	QP	P	
12	26.6053	6.05	24.78	30.83	50.00	-19.17	AVG	P	

Notes:

1. An initial pre-scan was performed on the line and neutral lines with peak detector.
2. Quasi-Peak and Average measurement were performed at the frequencies with maximized peak emission.
3. Measurement Level = Reading level + Correct Factor
4. The test data shows only the worst case GFSK 5730MHz mode



Temperature:	26°C	Relative Humidity:	54%
Pressure:	101kPa	Phase :	N
Test Voltage :	AC 120V/60Hz	Test Channel :	5730MHz

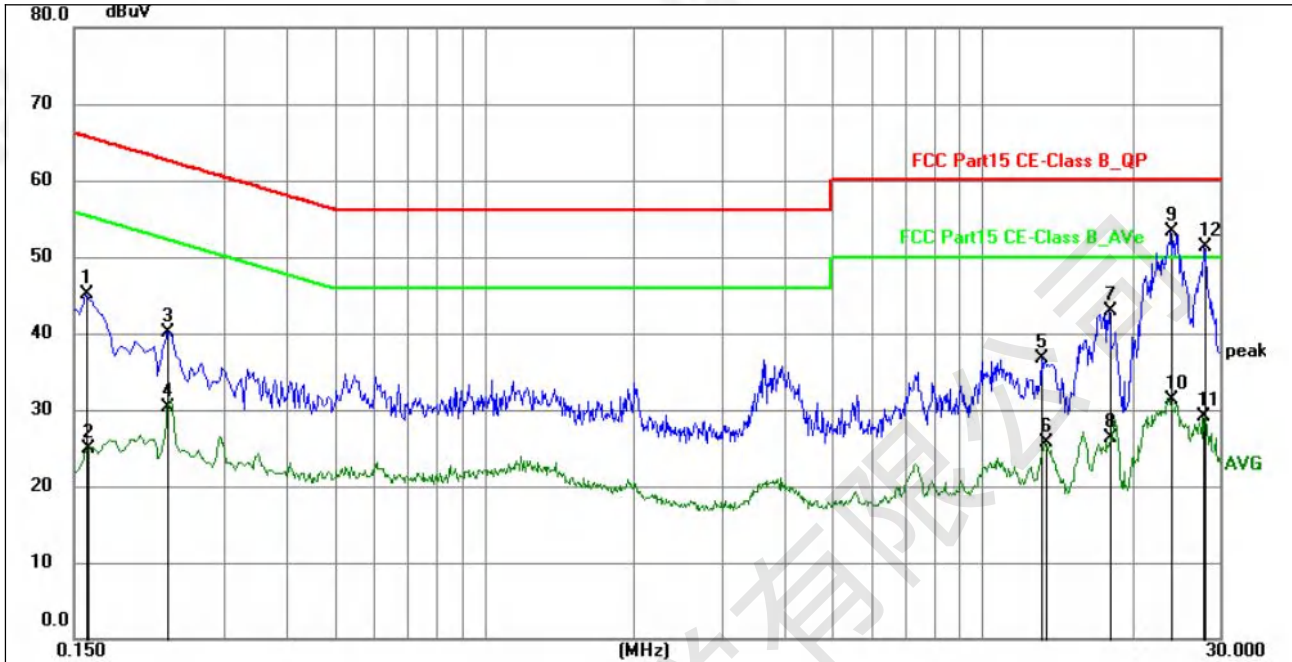

No.	Frequency (MHz)	Reading (dBuV)	Factor (dB)	Level (dBuV)	Limit (dBuV)	Margin (dB)	Detector	P/F	Remark
1	0.1590	24.17	20.87	45.04	65.52	-20.48	QP	P	
2	0.1598	3.97	20.87	24.84	55.47	-30.63	AVG	P	
3	0.2310	19.07	20.99	40.06	62.41	-22.35	QP	P	
4	0.2310	9.41	20.99	30.40	52.41	-22.01	AVG	P	
5	13.1955	14.11	22.60	36.71	60.00	-23.29	QP	P	
6	13.3980	3.07	22.63	25.70	50.00	-24.30	AVG	P	
7	17.9834	19.42	23.43	42.85	60.00	-17.15	QP	P	
8	18.1185	2.88	23.45	26.33	50.00	-23.67	AVG	P	
9	23.9189	29.00	24.39	53.39	60.00	-6.61	QP	P	
10	23.9189	6.94	24.39	31.33	50.00	-18.67	AVG	P	
11	27.7755	4.21	24.99	29.20	50.00	-20.80	AVG	P	
12	27.8835	26.30	25.00	51.30	60.00	-8.70	QP	P	

Notes:

1. An initial pre-scan was performed on the line and neutral lines with peak detector.
2. Quasi-Peak and Average measurement were performed at the frequencies with maximized peak emission.
3. Measurement Level = Reading level + Correct Factor
4. The test data shows only the worst case GFSK 5730MHz mode



4.2 Radiated emissions

Test Requirement:	FCC Part15 C Section 15.209/15.249				
Test Method:	ANSI C63.10:2013				
Test Frequency Range:	9kHz to 25GHz				
Test site:	Measurement Distance: 3m				
Receiver setup:	Frequency	Detector	RBW	VBW	Value
	9KHz-150KHz	Quasi-peak	200Hz	MX5Hz	Quasi-peak
	150KHz-30MHz	Quasi-peak	9KHz	30KHz	Quasi-peak
	30MHz-1GHz	Quasi-peak	100KHz	300KHz	Quasi-peak
	Above 1GHz	Peak	1MHz	3MHz	Peak
Peak		1MHz	10Hz	Average	

4.2.1 Radiated Emission Limits

Frequencies (MHz)	Field Strength (micorvolts/meter)	Measurement Distance (meters)
0.009~0.490	2400/F(KHz)	300
0.490~1.705	24000/F(KHz)	30
1.705~30.0	30	30
30~88	100	3
88~216	150	3
216~960	200	3
Above 960	500	3

FREQUENCY (MHz)	Limit (dBuV/m) (at 3M)	
	PEAK	AVERAGE
Above 1000	74	54

Notes:

- (1) The limit for radiated test was performed according to FCC PART 15C.
- (2) The tighter limit applies at the band edges.
- (3) Emission level (dBuV/m)=20log Emission level (uV/m).

LIMITS OF RADIATED EMISSION MEASUREMENT

Fundamental Frequency	Field Strength of Fundamental @3m (millivolts/meter)	Average Limit @3m (dBuV/m)	Peak Limit @3m (dBuV/m)
900-928MHz	50	94	114
2400-2483.5MHz	50	94	114
5725-5875MHz	50	94	114
24.0-24.25GHz	250	108	128

Note :

1. Average Limit (dBuV/m)=20×log[1000×Field Strength (mV/m)].
2. Peak Limit (dBuV/m)= Average Limit (dBuV/m)+20dB



4.2.2 TEST PROCEDURE

Below 1GHz test procedure as below:

- a. The EUT was placed on the top of a rotating table 0.8 meters above the ground at a 3 meter semi-anechoic chamber. The table was rotated 360 degrees to determine the position of the highest radiation.
- b. The EUT was set 3 meters away from the interference-receiving antenna, which was mounted on the top of a variable-height antenna tower.
- c. The antenna height is varied from one meter to four meters above the ground to determine the maximum value of the field strength. Both horizontal and vertical polarizations of the antenna are set to make the measurement.
- d. For each suspected emission, the EUT was arranged to its worst case and then the antenna was tuned to heights from 1 meter to 4 meters (for the test frequency of below 30MHz, the antenna was tuned to heights 1 meter) and the rotatable table was turned from 0 degrees to 360 degrees to find the maximum reading.
- e. The test-receiver system was set to Peak Detect Function and Specified Bandwidth with Maximum Hold Mode.
- f. If the emission level of the EUT in peak mode was 10dB lower than the limit specified, then testing could be stopped and the peak values of the EUT would be reported. Otherwise the emissions that did not have 10dB margin would be re-tested one by one using peak, quasi-peak or average method as specified and then reported in a data sheet.

Above 1GHz test procedure as below:

- g. Different between above is the test site, change from Semi- Anechoic Chamber to fully Anechoic Chamber and change form table 0.8 metre to 1.5 metre(Above 18GHz the distance is 1 meter and table is 1.5 metre).
- h. Test the EUT in the lowest channel ,the middle channel ,the Highest channel

Note:

Both horizontal and vertical antenna polarities were tested and performed pretest to three orthogonal axis. The worst case emissions were reported

4.2.3 DEVIATION FROM TEST STANDARD

No deviation

4.2.4 TEST SETUP

(A) Radiated Emission Test-Up Frequency Below 30MHz

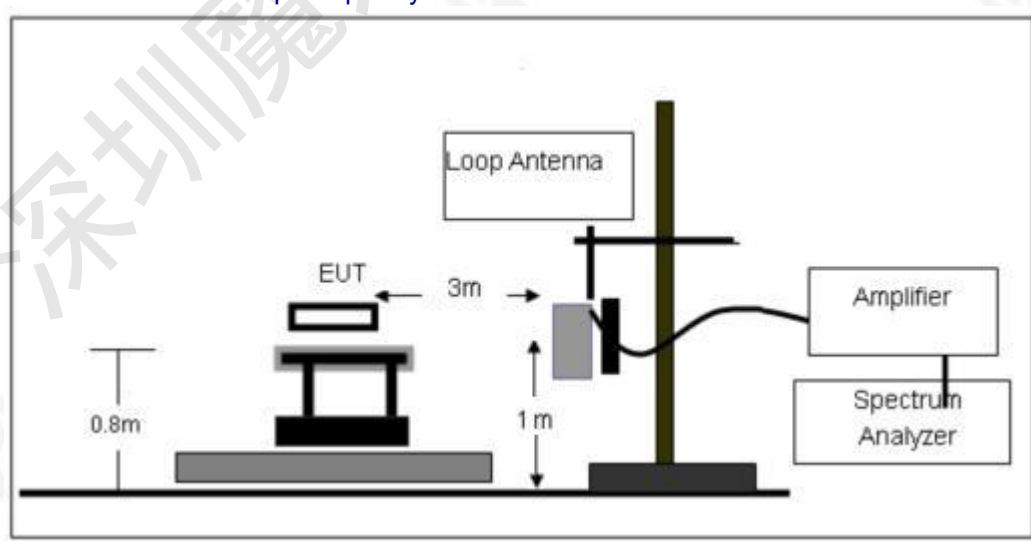



(B) Radiated Emission Test-Up Frequency 30MHz~1GHz

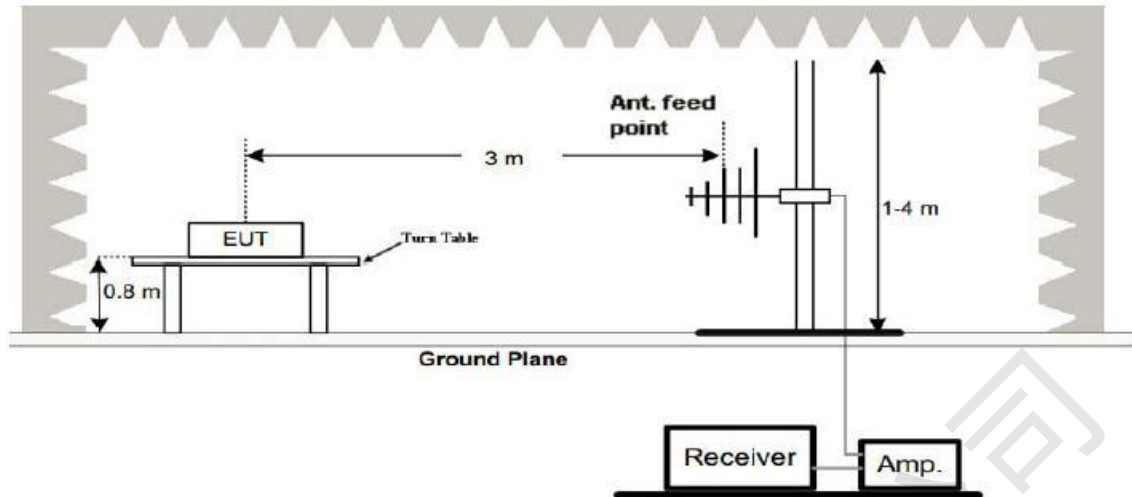

(C) Radiated Emission Test-Up Frequency Above 1GHz

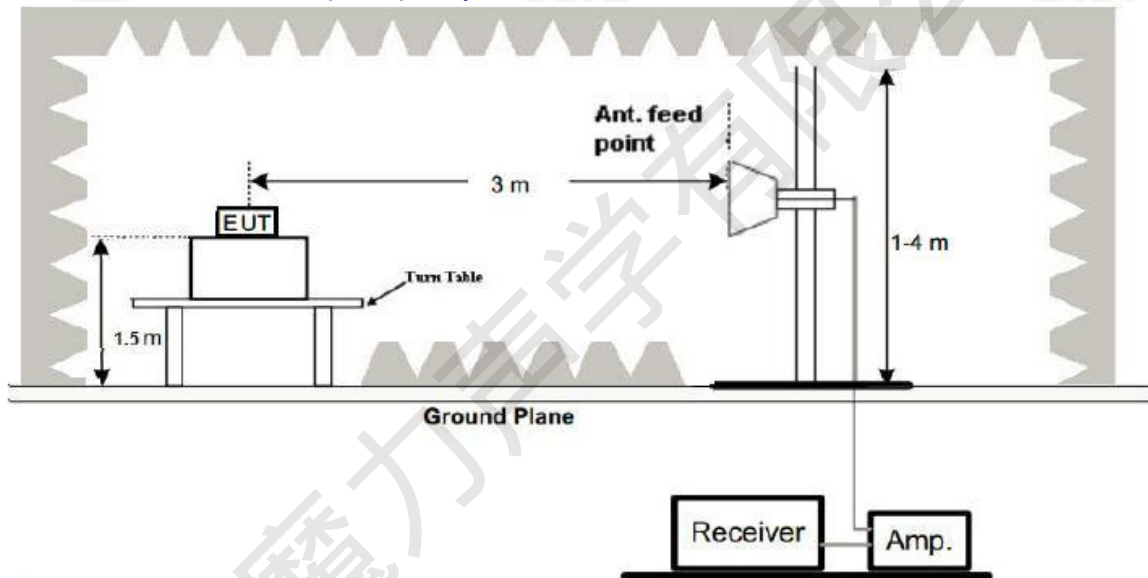

4.2.5 EUT OPERATING CONDITIONS

The EUT tested system was configured as the statements of 2.4 Unless otherwise a special operating condition is specified in the follows during the testing.

4.2.6 TEST RESULTS

Between 9KHz – 30MHz

The emission from 9 kHz to 30MHz was pre-tested and found the result was 20dB lower than the limit, and according to 15.31(o) & RSS-Gen 6.13, the test result no need to reported.



Between 30MHz – 1GHz

Temperature:	26°C	Relative Humidity:	54%
Pressure:	101 kPa	Polarization:	Horizontal
Test Voltage:	DC 5V	Test Channel :	5730MHz

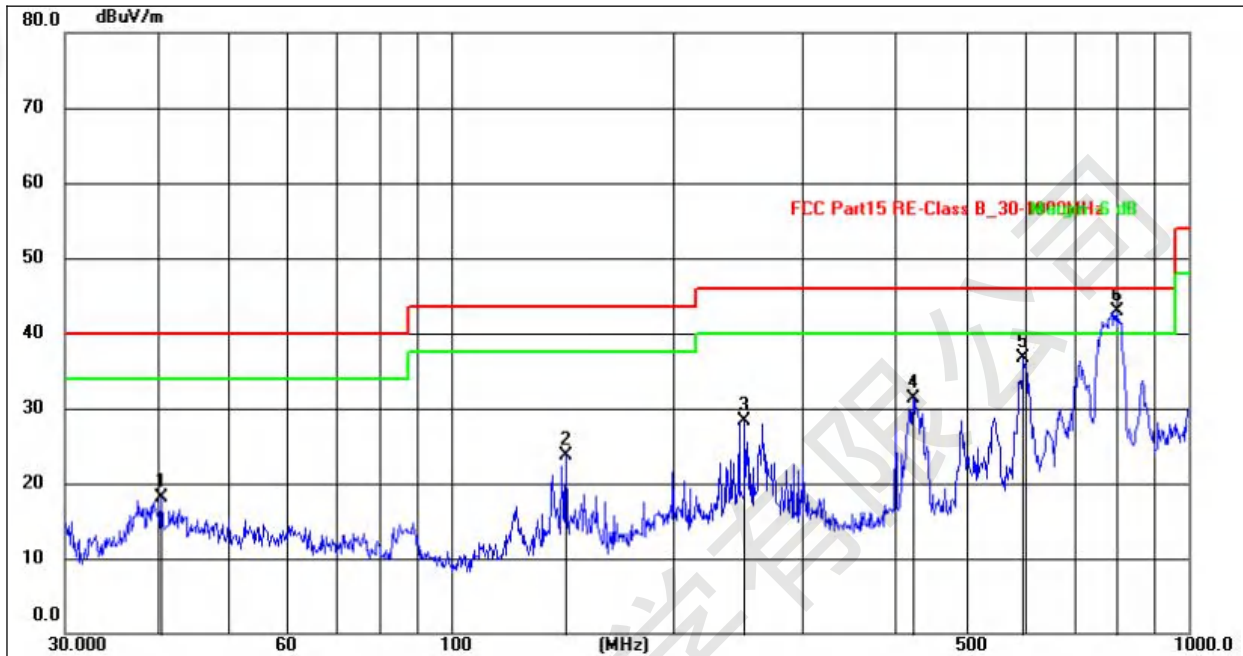

No.	Frequency (MHz)	Reading (dBuV)	Factor (dB/m)	Level (dBuV/m)	Limit (dBuV/m)	Margin (dB)	Detector
1	40.5591	32.14	-14.13	18.01	40.00	-21.99	QP
2	143.3257	40.61	-16.81	23.80	43.50	-19.70	QP
3	250.3009	44.26	-15.90	28.36	46.00	-17.64	QP
4	423.5402	46.74	-15.40	31.34	46.00	-14.66	QP
5	597.2232	45.53	-8.89	36.64	46.00	-9.36	QP
6	798.9796	49.79	-6.94	42.85	46.00	-3.15	QP



Temperature:	26°C	Relative Humidity:	54%
Pressure:	101kPa	Polarization:	Vertical
Test Voltage:	DC 5V	Test Channel :	5730MHz

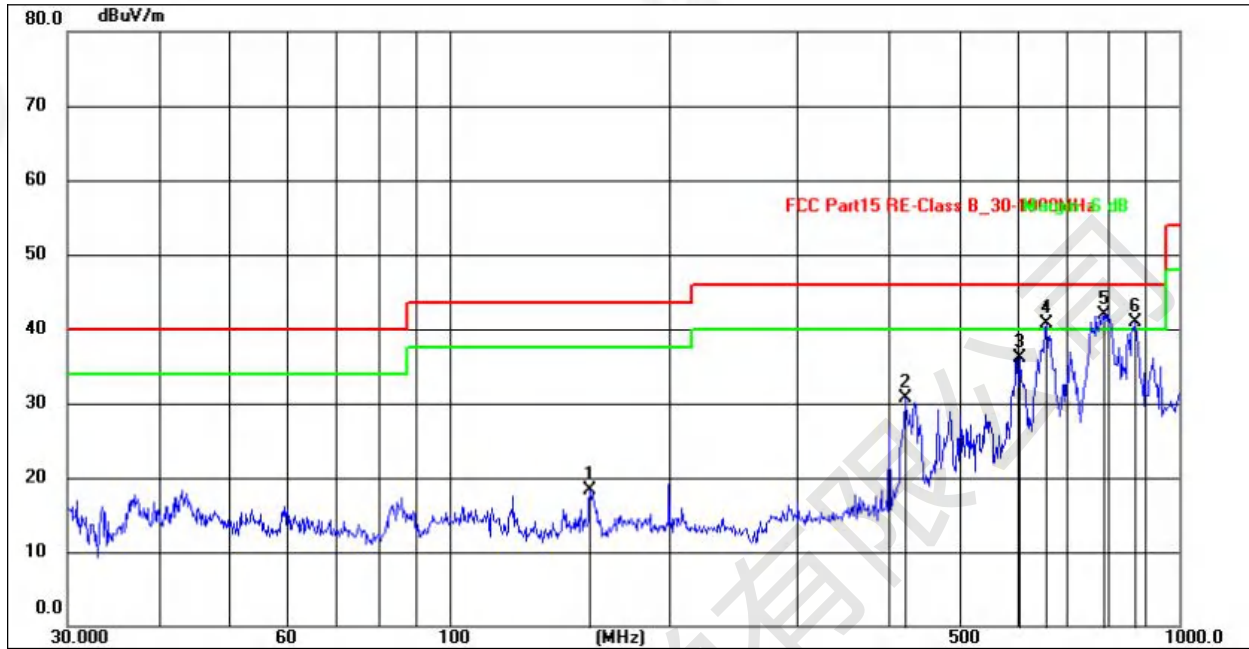

No.	Frequency (MHz)	Reading (dBuV)	Factor (dB/m)	Level (dBuV/m)	Limit (dBuV/m)	Margin (dB)	Detector
1	155.9100	38.68	-20.34	18.34	43.50	-25.16	QP
2	422.0577	44.95	-14.28	30.67	46.00	-15.33	QP
3	605.6592	43.82	-7.76	36.06	46.00	-9.94	QP
4	658.8360	48.43	-7.69	40.74	46.00	-5.26	QP
5	787.8509	45.91	-4.07	41.84	46.00	-4.16	QP
6	869.1300	42.56	-1.62	40.94	46.00	-5.06	QP

Remarks:

- 1.Final Level =Receiver Read level + Antenna Factor + Cable Loss – Preamplifier Factor
- 2.The emission levels of other frequencies are very lower than the limit and not show in test report.
- 3.The test data shows only the worst case 5730MHz.



1GHz~25GHz

Polar (H/V)	Frequency	Meter Reading	Pre-amplifier	Cable Loss	Antenna Factor	Emission Level	Limits	Margin	Detector Type
	(MHz)	(dBuV)	(dB)	(dB)	(dB)	(dBuV/m)	(dBuV/m)	(dB)	
Low Channel:5730MHz									
V	5730	80.07	30.64	5.26	24.22	78.91	114.00	-35.09	PK
V	5730	84.78	30.64	5.26	24.22	83.62	94.00	-10.38	AV
V	11460	51.93	30.55	5.77	24.66	51.81	74.00	-22.19	PK
V	11460	51.95	30.55	5.77	24.66	51.83	54.00	-2.17	AV
V	17190	50.93	30.33	6.32	24.55	51.47	74.00	-22.53	PK
V	17190	47.63	30.33	6.32	24.55	48.17	54.00	-5.83	AV
V	22920	51.34	30.85	7.45	24.69	52.63	74.00	-21.37	PK
V	22920	50.85	30.85	7.45	24.69	52.14	54.00	-1.86	AV
H	5730	83.49	30.64	5.26	24.22	82.33	114.00	-31.67	PK
H	5730	84.17	30.64	5.26	24.22	83.01	94.00	-10.99	AV
H	11460	52.30	30.55	5.77	24.66	52.18	74.00	-21.82	PK
H	11460	49.58	30.55	5.77	24.66	49.46	54.00	-4.54	AV
H	17190	51.53	30.33	6.32	24.55	52.07	74.00	-21.93	PK
H	17190	49.62	30.33	6.32	24.55	50.16	54.00	-3.84	AV
H	22920	51.34	30.85	7.45	24.69	52.63	74.00	-21.37	PK
H	22920	49.00	30.85	7.45	24.69	50.29	54.00	-3.71	AV

深圳魔力



Polar (H/V)	Frequency	Meter Reading	Pre-amplifier	Cable Loss	Antenna Factor	Emission Level	Limits	Margin	Detector Type
	(MHz)	(dBuV)	(dB)	(dB)	(dB)	(dBuV/m)	(dBuV/m)	(dB)	
Middle Channel:5790MHz									
V	5790	82.14	30.64	5.26	24.22	80.98	114.00	-33.02	PK
V	5790	83.02	30.64	5.26	24.22	81.86	94.00	-12.14	AV
V	11580	50.01	30.55	5.77	24.66	49.89	74.00	-24.11	PK
V	11580	48.07	30.55	5.77	24.66	47.95	54.00	-6.05	AV
V	17370	49.07	30.33	6.32	24.55	49.61	74.00	-24.39	PK
V	17370	48.57	30.33	6.32	24.55	49.11	54.00	-4.89	AV
V	23160	48.21	30.85	7.45	24.69	49.50	74.00	-24.50	PK
V	23160	50.97	30.85	7.45	24.69	52.26	54.00	-1.74	AV
H	5790	80.82	30.64	5.26	24.22	79.66	114.00	-34.34	PK
H	5790	81.48	30.64	5.26	24.22	80.32	94.00	-13.68	AV
H	11580	52.48	30.55	5.77	24.66	52.36	74.00	-21.64	PK
H	11580	51.44	30.55	5.77	24.66	51.32	54.00	-2.68	AV
H	17370	47.27	30.33	6.32	24.55	47.81	74.00	-26.19	PK
H	17370	49.10	30.33	6.32	24.55	49.64	54.00	-4.36	AV
H	23160	50.89	30.85	7.45	24.69	52.18	74.00	-21.82	PK
H	23160	47.86	30.85	7.45	24.69	49.15	54.00	-4.85	AV



Polar (H/V)	Frequency	Meter Reading	Pre-amplifier	Cable Loss	Antenna Factor	Emission Level	Limits	Margin	Detector Type
	(MHz)	(dBuV)	(dB)	(dB)	(dB)	(dBuV/m)	(dBuV/m)	(dB)	
High Channel:5850MHz									
V	5850	83.27	30.64	5.26	24.22	82.11	114.00	-31.89	PK
V	5850	81.96	30.64	5.26	24.22	80.80	94.00	-13.20	AV
V	11700	51.25	30.55	5.77	24.66	51.13	74.00	-22.87	PK
V	11700	50.50	30.55	5.77	24.66	50.38	54.00	-3.62	AV
V	17550	47.70	30.33	6.32	24.55	48.24	74.00	-25.76	PK
V	17550	49.01	30.33	6.32	24.55	49.55	54.00	-4.45	AV
V	23400	51.58	30.85	7.45	24.69	52.87	74.00	-21.13	PK
V	23400	48.79	30.85	7.45	24.69	50.08	54.00	-3.92	AV
H	5850	82.15	30.64	5.26	24.22	80.99	114.00	-33.01	PK
H	5850	81.16	30.64	5.26	24.22	80.00	94.00	-14.00	AV
H	11700	53.34	30.55	5.77	24.66	53.22	74.00	-20.78	PK
H	11700	47.74	30.55	5.77	24.66	47.62	54.00	-6.38	AV
H	17550	51.22	30.33	6.32	24.55	51.76	74.00	-22.24	PK
H	17550	48.23	30.33	6.32	24.55	48.77	54.00	-5.23	AV
H	23400	48.85	30.85	7.45	24.69	50.14	74.00	-23.86	PK
H	23400	47.34	30.85	7.45	24.69	48.63	54.00	-5.37	AV

Remark:

1. Emission Level = Meter Reading + Antenna Factor + Cable Loss – Pre-amplifier,
Margin= Emission Level - Limit
2. If peak below the average limit, the average emission was no test.
3. The amplitude of spurious emissions which are attenuated by more than 20dB below the permissible value has no need to be reported.



5. RADIATED BAND EMISSION MEASUREMENT

5.1 Test Requirement:

Test Requirement:	FCC Part15 C Section 15.205 and 15.209				
Test Method:	ANSI C63.10: 2013				
Test Frequency Range:	All of the restrict bands were tested, only the worst band's (outside of 5725-5875 MHz) data was showed.				
Test site:	Measurement Distance: 3m				
Receiver setup:	Frequency	Detector	RBW	VBW	Value
	Above 1GHz	Peak	1MHz	3MHz	Peak
		Average	1MHz	3MHz	Average

LIMITS OF RADIATED EMISSION MEASUREMENT (Above 1000MHz)

FREQUENCY (MHz)	Limit (dBuV/m) (at 3M)	
	PEAK	AVERAGE
Above 1000	74	54

Notes:

- (1) The limit for radiated test was performed according to FCC PART 15C.
- (2) The tighter limit applies at the band edges.
- (3) Emission level (dBuV/m)=20log Emission level (uV/m).

Spectrum Parameter	Setting
Attenuation	Auto
Start Frequency	5725MHz
Stop Frequency	5875MHz
RB / VB (emission in restricted band)	1 MHz / 3 MHz for Peak, 1 MHz / 3MHz for Average

5.2 TEST PROCEDURE

Above 1GHz test procedure as below:

- a. 1. The EUT was placed on the top of a rotating table 0.8meters above the ground at a 3 meter camber. The table was rotated 360 degrees to determine the position of the highest radiation.
- b. The EUT was set 3 meters away from the interference-receiving antenna, which was mounted on the top of a variable-height antenna tower.
- c. The antenna height is varied from one meter to four meters above the ground to determine the maximum value of the field strength. Both horizontal and vertical polarizations of the antenna are set to make the measurement.
- d. For each suspected emission, the EUT was arranged to its worst case and then the antenna was tuned to heights from 1 meter to 4 meters and the rota table was turned from 0 degrees to 360 degrees to find the maximum reading.
- e. The test-receiver system was set to Peak Detect Function and Specified Bandwidth with Maximum Hold Mode.
- f. If the emission level of the EUT in peak mode was 10dB lower than the limit specified, then testing could be stopped and the peak values of the EUT would be reported. Otherwise the emissions that did not have 10dB margin would be re-tested one by one using peak, quasi-peak or average method as specified and then reported in a data sheet.
- g. Test the EUT in the lowest channel,the Highest channel

Note:

Both horizontal and vertical antenna polarities were tested and performed pretest to three orthogonal axis. The worst case emissions were reported



5.3 DEVIATION FROM TEST STANDARD

No deviation

5.4 TEST SETUP

Radiated Emission Test-Up Frequency Above 1GHz

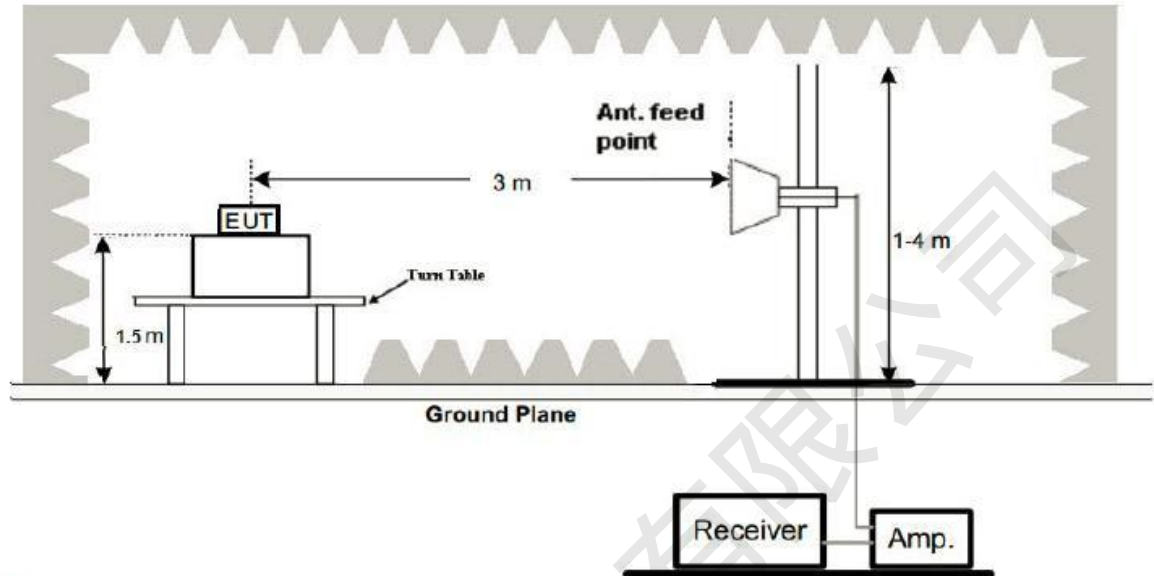

5.5 EUT OPERATING CONDITIONS

The EUT tested system was configured as the statements of 2.3 Unless otherwise a special operating condition is specified in the follows during the testing.



5.6 TEST RESULT

Temperature	26°C	Relative Humidity:	54%
Pressure	101kPa	Test Voltage	DC 5V
Test Mode	5730MHz	Polarization	Horizontal

Peak Value



Average Value

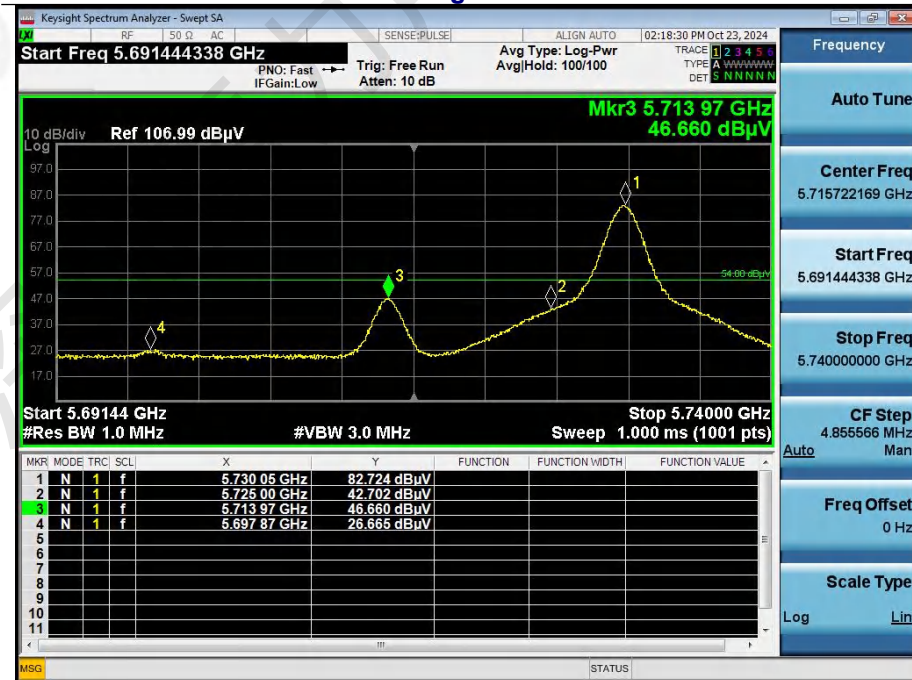



Temperature	26°C	Relative Humidity:	54%
Pressure	101kPa	Test Voltage	DC 5V
Test Mode	5730MHz	Polarization	Vertical

Peak Value

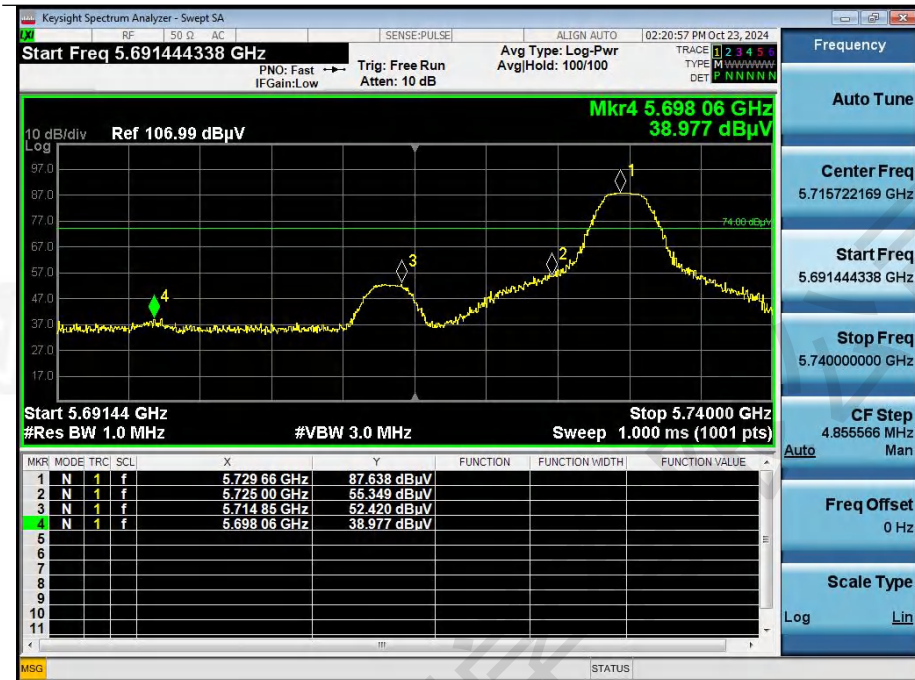

Average Value

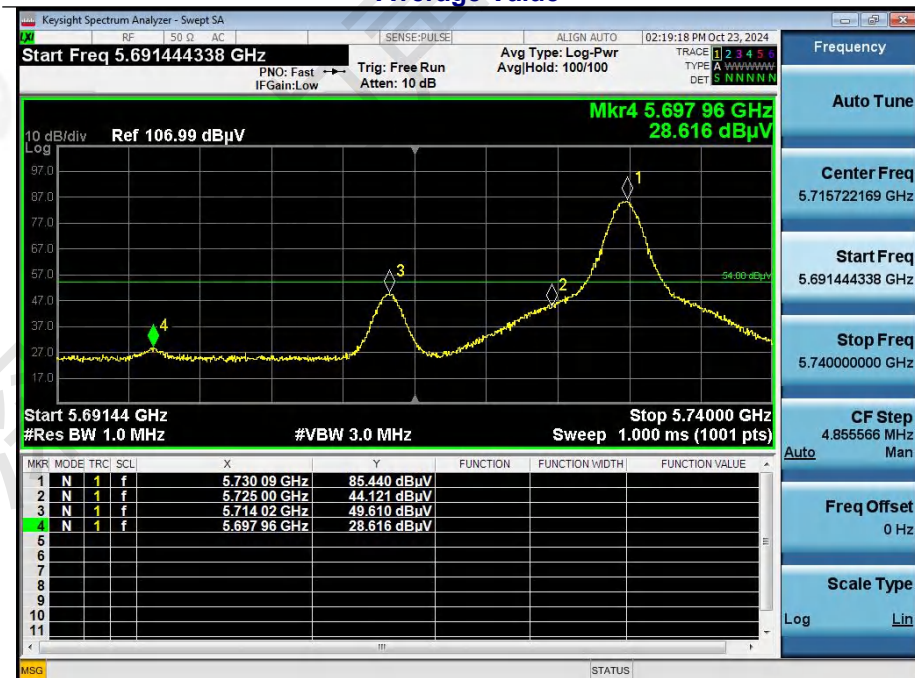



Temperature	26°C	Relative Humidity:	54%
Pressure	101kPa	Test Voltage	DC 5V
Test Mode	5850MHz	Polarization	Horizontal

Peak Value

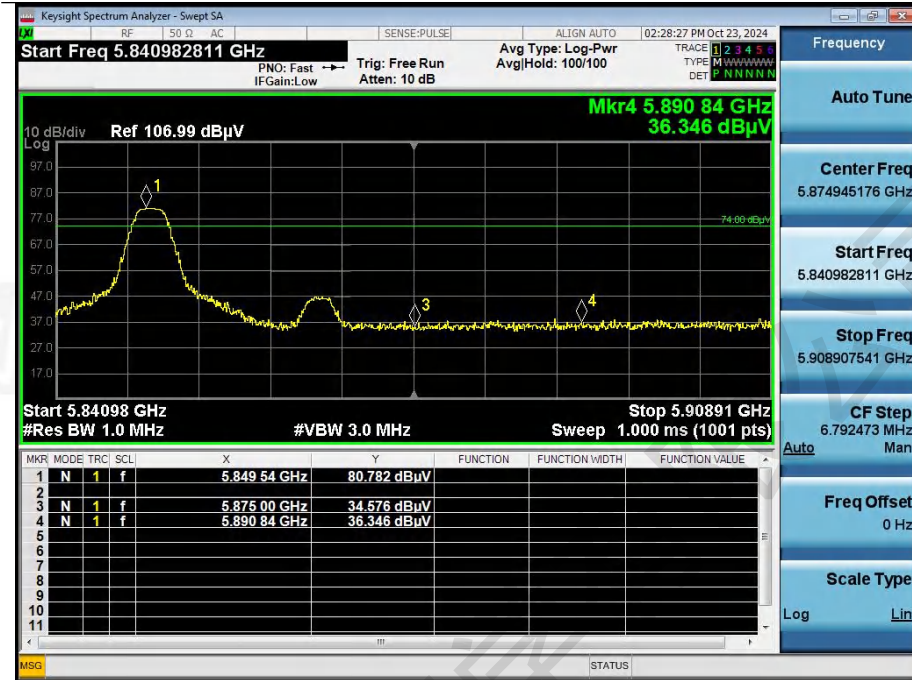

Average Value

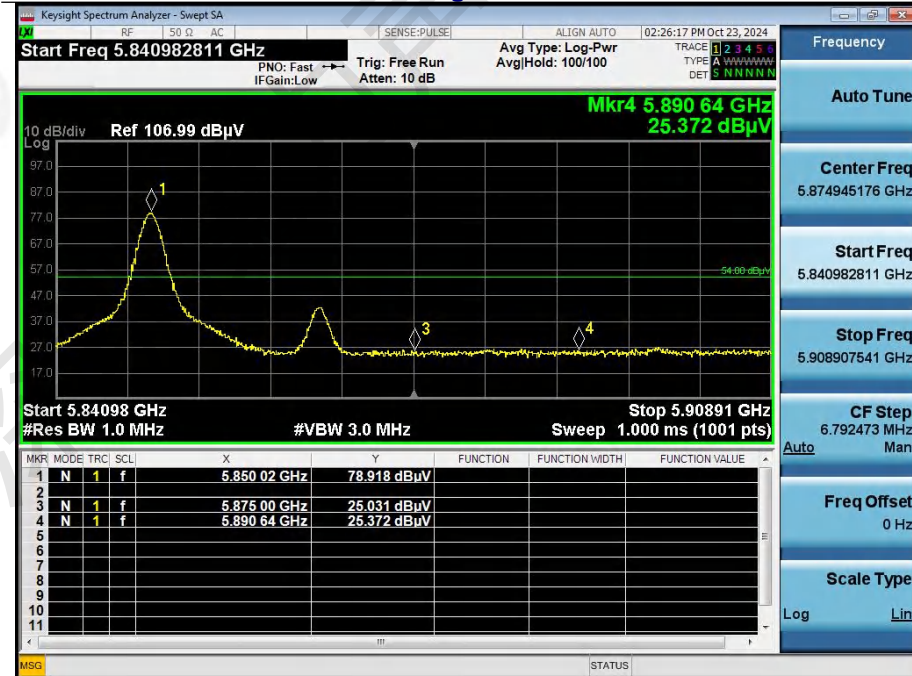



Temperature	21.8°C	Relative Humidity	58%
Pressure	101kPa	Test Voltage	DC 5V
Test Mode	5850MHz	Polarization	Vertical

Peak Value

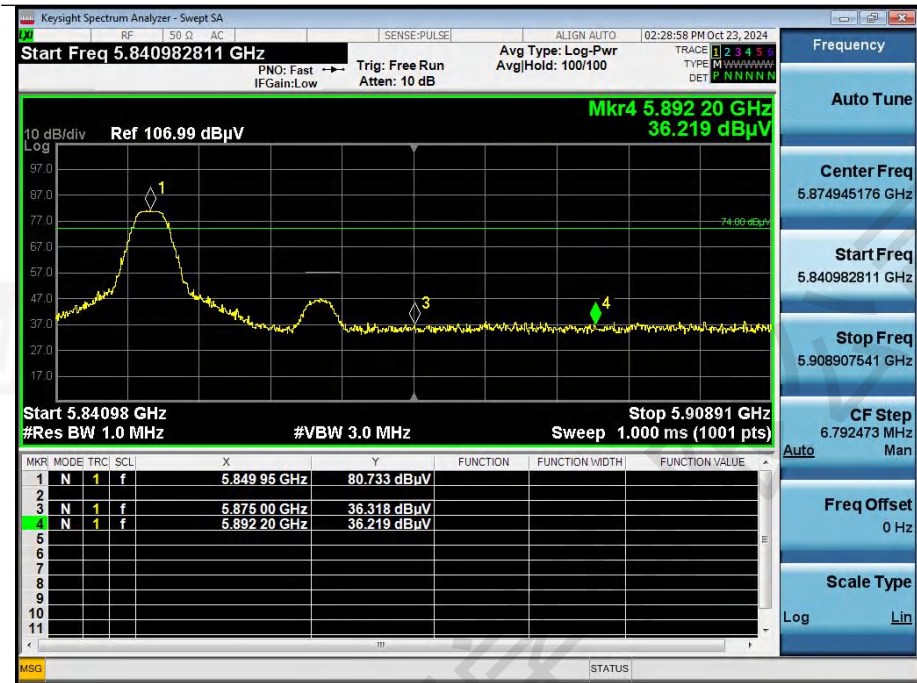

Average Value

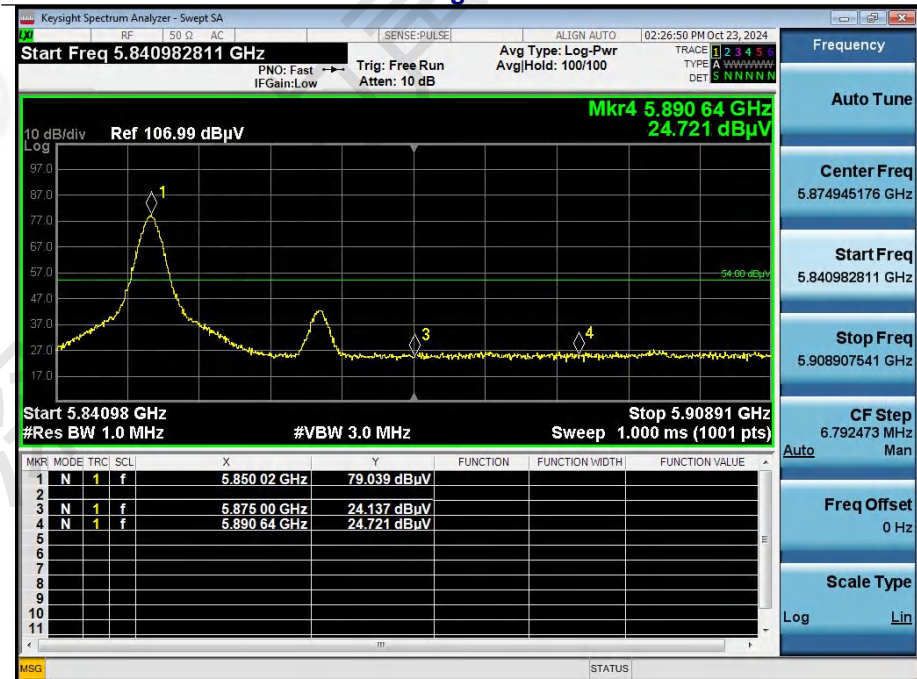



6. 20DB BANDWIDTH

Test Requirement:	FCC Part15 C Section 15.215
Test Method:	ANSI C63.10:2013

6.1 Test Setup



6.2 Limit

FCC Part15 (15.249) , Subpart C			
Section	Test Item	Frequency Range (MHz)	Result
15.249(c)	Bandwidth	5725-5875	PASS

6.3 Test procedure

1. Set resolution bandwidth (RBW) = 1~5% of 20dB BW
2. Set the video bandwidth (VBW) ≥ 3 x RBW.
3. Detector = Peak.
4. Trace mode = max hold.
5. Sweep = auto couple.
6. Allow the trace to stabilize.
7. Measure the maximum width of the emission that is constrained by the frequencies associated with the two outermost amplitude points (upper and lower frequencies) that are attenuated by 6 dB relative to the maximum level measured in the fundamental emission.

6.4 DEVIATION FROM STANDARD

No deviation.

6.5 Test Result

Mode	Test channel	20dB Emission Bandwidth (MHz)	Result
FHSS	Lowest	3.315	Pass
	Middle	3.245	
	Highest	3.646	



Test plots

5730MHz

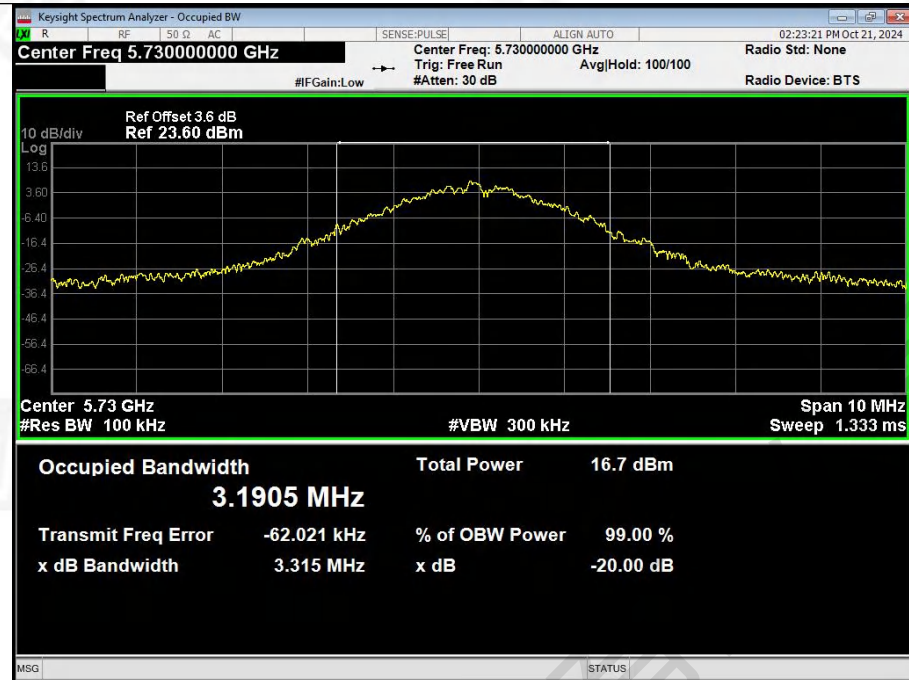

5790MHz

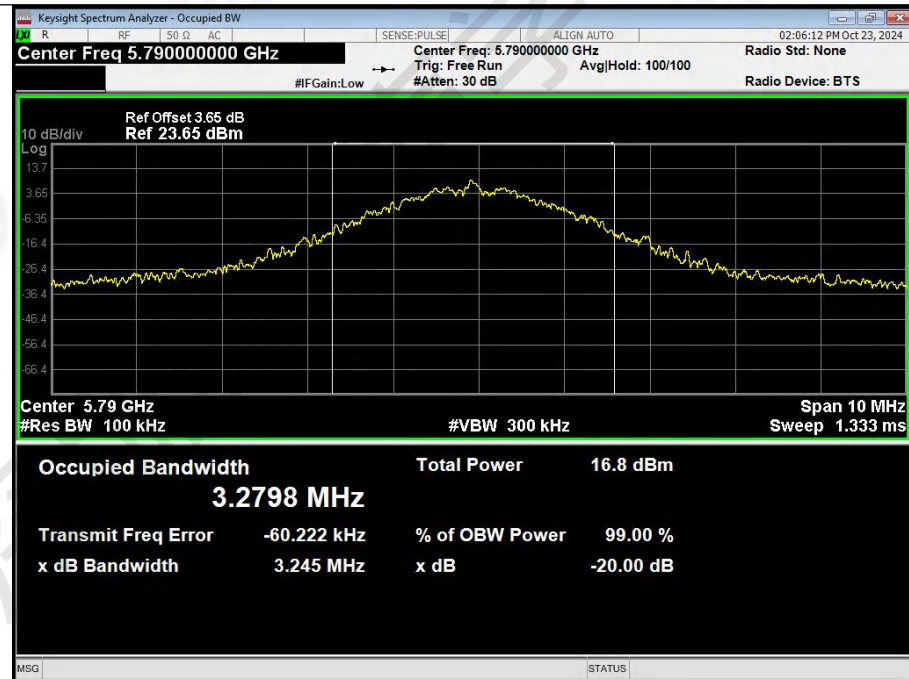



5850MHz

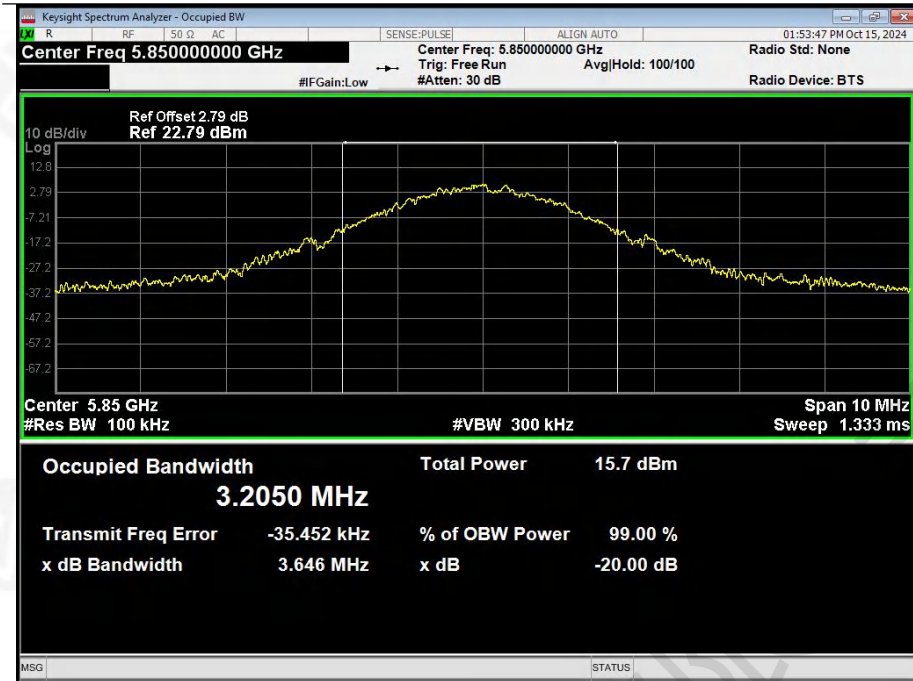

深圳魔力声学有限公司



7. Antenna Requirement

Standard requirement:	FCC Part15 C Section 15.203
15.203 requirement:	An intentional radiator shall be designed to ensure that no antenna other than that furnished by the responsible party shall be used with the device. The use of a permanently attached antenna or of an antenna that uses a unique coupling to the intentional radiator, the manufacturer may design the unit so that a broken antenna can be replaced by the user, but the use of a standard antenna jack or electrical connector is prohibited.
EUT Antenna:	The antenna is External Antenna, the best case gain of the antennas is 3dBi, reference to the appendix II for details

深圳魔力声学有限公司



8. Test Setup Photo

Reference to the appendix I for details.

9. EUT Constructional Details

Reference to the appendix II for details.

※※※※ END OF REPORT ※※※※

深圳魔力声学有限公司